

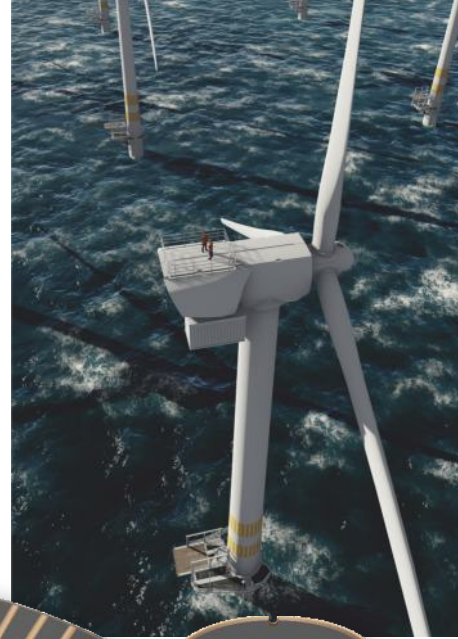

**GGB**  
BY TIMKEN

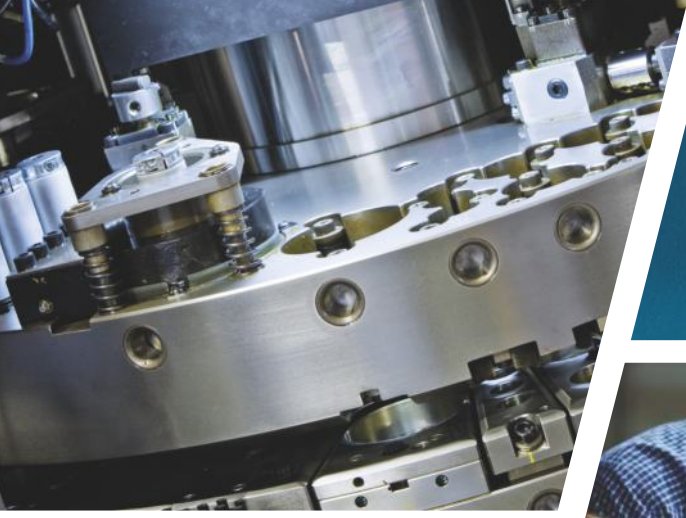

GGB DU<sup>®</sup> and DU-B  
METAL-POLYMER SELF-LUBRICATING BEARING SOLUTIONS





# PUSHING BOUNDARIES TO CO-CREATE A HIGHER QUALITY OF LIFE

GGB helps create a world of motion with minimal frictional loss through plain bearing and surface engineering technologies. With R&D, testing and production facilities in the United States, Germany, France, Brazil, Slovakia and China, GGB partners with customers worldwide on customized tribological design solutions that are efficient and environmentally sustainable. GGB's engineers bring their expertise and passion for tribology to a wide range of industries, including automotive, aerospace and industrial manufacturing. To learn more about tribology for surface engineering from GGB, visit [www.ggbearings.com/en](http://www.ggbearings.com/en).

Our products are used in tens of thousands of critical applications every day on our planet. It is always our goal to provide superior, high-quality solutions for our customers' needs, no matter where those demands take our products. From space vehicles to golf carts and virtually everything in between; we offer the industry's most extensive range of high performance, maintenance-free bearing solutions for a multitude of applications:

- [Aerospace](#)
- [Agricultural](#)
- [Automotive](#)
- [Construction](#)
- [E-Mobility](#)
- [Energy](#)
- [Fluid Power](#)
- [Industrial](#)
- [Medical](#)
- [Mining](#)
- [Oil & Gas](#)
- [Primary Metals](#)
- [Railway](#)
- [Recreation](#)

# The GGB Advantage



## LOWER SYSTEM COST

GGB bearings reduce shaft costs by eliminating the need for hardening and machining grease paths. Their compact, one-piece construction provides space and weight savings and simplifies assembly.



## LOW-FRICTION, HIGH WEAR RESISTANCE

Low coefficients of friction eliminate the need for lubrication, while providing smooth operation, reducing wear and extending service life. Low-friction also eliminates the effects of stick-slip or "stiction" during start up.



## MAINTENANCE-FREE

GGB bearings are self-lubricating, making them ideal for applications requiring long bearing life without continuous maintenance, as well as operating conditions with inadequate or no lubrication.



## ENVIRONMENTAL

Greaseless, lead-free GGB bearings comply with increasingly stringent environmental regulations such as the EU RoHS directive restricting the use of hazardous substances in certain types of electrical and electronic equipment.



## CUSTOMER SUPPORT

GGB's flexible production platform and extensive supply network assure quick turnaround and timely deliveries. In addition, we offer local applications engineering and technical support.

# The Highest Standards in Quality



## SAFETY

Our deep-rooted culture of safety places a relentless focus on creating a secure, healthy work environment for all. As one of our core values, safety is essential for us to achieve our goal of having the safest employees in the industry.



## EXCELLENCE

Our world-class manufacturing plants in the United States, Brazil, China, Germany, France and Slovakia are certified in quality and excellence according to ISO 9001, IATF 16949, ISO 14001 and ISO 45001. This allows us to access the industry's best practices while aligning our management system with global standards.

For a complete listing of our certifications, please visit our website:

[www.ggbearings.com/en/certificates](http://www.ggbearings.com/en/certificates)



## RESPECT

Our teams work together with mutual respect regardless of background, nationality, or function, embracing the diversity of people and learning from one another - after all, with respect comes both individual and group growth.

# GGB Who We Are



## **GGB'S HISTORY AS THE GLOBAL LEADER IN PLAIN BEARING TECHNOLOGIES DATES BACK MORE THAN 120 YEARS.**

Beginning with the founding of Glacier Antifriction Metal Company in 1899 and later introducing the industry-leading DU® bearing in 1965, GGB has continued to create innovative technologies and solutions that improve safety, performance, and profitability in a wide range of markets. Today, our products can be found everywhere - from scientific vessels at the bottom of the ocean to racecars speeding down the tarmac to jumbo jets slicing through the sky to the Curiosity rover exploring the surface of Mars.

Throughout our history, safety, excellence, and respect have formed the foundational values for the entire GGB family. They are of paramount importance as we seek to maximize personal possibility, achieve excellence, and establish open, creative work environments



# Table of Contents

---

<b>1 Introduction</b>	<b>7</b>	<b>3.8 Calculation of Bearing</b>	<b>20</b>
1.1 Applications	7	Service Life	20
1.2 Characteristics and Advantages	7	Specific Load $p$	20
1.3 Basic Forms Available	8	High Load Factor $a_E$	20
1.4 Materials	8	Modified $pU$ Factor	20
<b>2 Material</b>	<b>9</b>	Estimation of Bearing Life $L_H$	21
2.1 Structure	9	Bore Burnishing	21
2.2 Dry Wear Mechanism	9	Slideways	21
2.3 Physical, Mechanical and Electrical Properties	11	<b>3.9 Worked Examples</b>	<b>22</b>
2.4 Chemical Properties	12	<b>4 Lubrication</b>	<b>24</b>
Electrochemical Corrosion	12	4.1 Lubricants	24
2.5 Frictional Properties	12	4.2 Tribology	24
<b>3 Performance</b>	<b>14</b>	Hydrodynamic Lubrication	24
3.1 Design Factors	14	Mixed Film Lubrication	25
Calculation	14	Boundary Lubrication	25
3.2 Specific Load $p$	14	<b>4.3 Characteristics of Lubricated DU® Bearings</b>	<b>25</b>
3.3 Specific Load Limit $p_{lim}$	15	4.4 Design Guidance for Lubricated Applications	26
3.4 Sliding Speed $U$	15	4.5 Clearances for Lubricated Operation	27
Continuous Rotation	15	4.6 Mating Surface Finish for Lubricated Operation	27
Oscillating Movement	15	4.7 Grooving for Lubricated Operation	27
3.5 $pU$ Factor	16	4.8 Grease Lubrication	27
3.6 Application Factors	16		
Temperature	16		
Mating Surface	17		
Bearing Size	17		
Bore Burnishing	18		
Type of Load	18		
3.7 Calculation of Bearing Size	19		
Calculation for Bushes	19		
Calculation for Thrust Washers	19		
Calculation for Slideways	19		

# Table of Contents

---

<b>5 Bearing Assembly</b>	<b>28</b>	<b>7 Standard Products</b>	<b>34</b>
Dimensions and Tolerances	28	7.1 DU® Cylindrical Bushes	34
<b>5.1 Allowance for Thermal Expansion</b>	<b>28</b>	7.2 DU® Flanged Bushes	40
<b>5.2 Tolerances for minimum clearance</b>	<b>28</b>	7.3 DU® Flanged Washers	42
Sizing	29	7.4 DU® Thrust Washer	43
<b>5.3 Counterface Design</b>	<b>29</b>	7.5 DU-B Cylindrical Bushes	44
<b>5.4 Installation</b>	<b>30</b>	7.6 DU-B Flanged Bushes	47
Fitting of Cylindrical Bushes	30	7.7 DU® Cylindrical Bushes - Inch sizes	49
Fitting of Flanged Bushes	30	7.8 DU® Thrust Washers - Inch sizes	52
Insertion Forces	30	7.9 DU® Strip	53
Alignment	31	7.10 DU-B Strip	53
Sealing	31	7.11 DU® Strip - Inch sizes	53
<b>5.5 Axial Location</b>	<b>31</b>	<b>8 Test Methods</b>	<b>54</b>
Fitting of Thrust Washers	31	8.1 Measurement of Wrapped Bushes	54
Slideways	32	Test A of ISO 3547 Part 2	54
<b>6 Modification</b>	<b>33</b>	Test B (alternatively to Test A)	54
<b>6.1 Cutting and Machining</b>	<b>33</b>	Test C	54
Drilling Oil Holes	33	Measurement of Wall Thickness (alternatively to Test C)	54
Cutting Strip Material	33	Test D	54
<b>6.2 Electroplating</b>	<b>33</b>	<b>Formula Symbols and Designations</b>	<b>53</b>
DU Components	33	<b>9 Bearing Application Data Sheet</b>	<b>56</b>
Mating Surfaces	33	<b>Product Information</b>	<b>57</b>

# 1 Introduction

---

The purpose of this handbook is to provide comprehensive technical information on the characteristics of DU® and DU-B bearings. The information given permits designers to establish the correct size of bearing required and the expected life and performance. GGB Research and Development services are available to assist with unusual design problems.

Complete information on the range of DU® and DU-B standard stock products is given together with details of other DU® and DU-B products.

GGB is continually refining and extending its experimental and theoretical knowledge and, therefore, when using this brochure it is always worth-while to contact the Company should additional information be required.

As it is impossible to cover all conditions of operation which arise in practice, customers are advised to carry out prototype testing wherever possible.

## 1.1 APPLICATIONS

DU® and DU-B are suitable for

- rotating,
- oscillating,
- reciprocating and
- sliding movements.

Also available are DU® and DU-B related material compositions for specific applications, for example when increased corrosion resistance of the bearing material is required due to

- when improved corrosion resistance is required
- in the case of more stringent requirements as a result of environmental regulations
- when there is a tendency to fretting corrosion.

## 1.2 CHARACTERISTICS AND ADVANTAGES

- DU® and DU-B require no lubrication
- Provides maintenance free operation
- DU® and DU-B have a high pU capability
- DU® and DU-B exhibit low wear rate
- Seizure resistant
- Suitable for temperatures from -200 to +280 °C
- High static and dynamic load capacity
- Good frictional properties with negligible stick-slip
- Resists solvents
- No water absorption and therefore dimensionally stable
- DU® and DU-B are electrically conductive and show no electrostatic effects
- DU® and DU-B have good embedability and are tolerant of dusty environments
- Compact and light
- DU® and DU-B bearings are prefinished and require no machining after assembly

## 1.3 BASIC FORMS AVAILABLE

### Standard Components available from Stock.

These products are manufactured to international, national or GGB standard designs.

#### Metric and Imperial Sizes

— Cylindrical Bushes — Flanged Bushes\* — Thrust Washers — Flanged Washers\* — Strip Material \* Metric sizes only

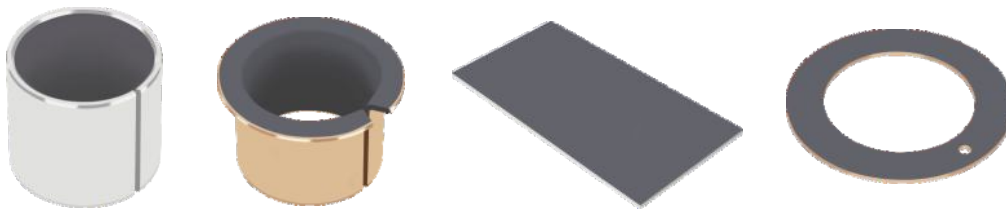

Fig. 1: Standard Components

### Non-Standard Components not available from Stock.

These products are manufactured to customers' requirements with or without GGB recommendations, and include for example:

— Modified Standard Components — Half Bearings — Flat Components — Deep Drawn Parts — Pressings — Stampings



Fig. 2: Non-Standard Components

## 1.4 MATERIALS

MATERIAL	BACKING	BEARING LINING	OPERATING TEMPERATURE [°C]		MAXIMUM LOAD $p_{lim}$ [Nmm <sup>2</sup> ]
DU®	Steel	PTFE+Lead	min -200	max +280	250
DU-B	Bronze	PTFE+Lead	min -200	max +280	140

Table 1: Characteristics of DU and DU-B



# 2 Material

## 2.1 STRUCTURE

### DU®

DU® and DU-B take advantage of the outstanding dry bearing properties of Polytetrafluoroethylene (PTFE) and combines them with strength, stability and good wear resistance, excellent heat conductivity and low thermal expansion.

DU® consists of three bonded layers: a steel backing strip and a porous bronze matrix, impregnated and overlaid with the PTFE/lead bearing material.

### DU-B

DU-B also consists of three layers, with a bronze backing replacing the steel backing strip. The structure is otherwise the same as that of DU®.

The bronze backing provides a high corrosion resistance, anti magnetic properties and a good thermal conductivity.



Fig. 3: DU Microsection



Fig. 4: DU-B Microsection

## 2.2 DRY WEAR MECHANISM

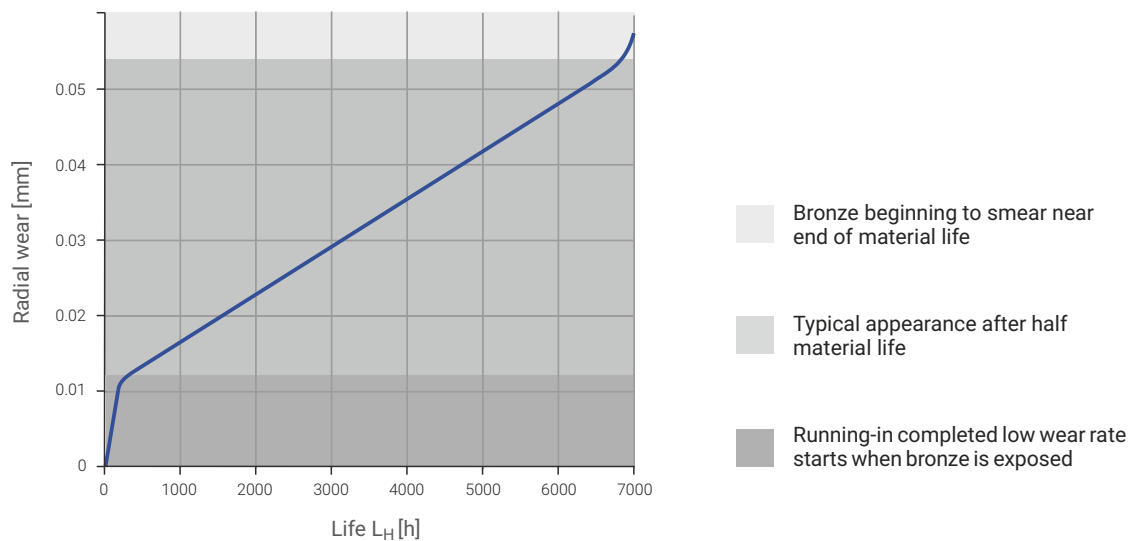

Fig. 5: Effect of wear on the DU bearing surface under dry operating conditions.

# 2 Material

## Running-in

During normal operation, a DU® bearing quickly beds in and the PTFE/lead overlay material removed during this period, typically 0,015 mm, is transferred to the mating surface and forms a physically bonded lubricant film.

The rubbing surface of the bearing often acquires a grey-green colour and the bronze matrix can be seen exposed over about 10 % of the bearing surface. Any excess of the PTFE/lead surface layer will be shed as fine feathery particles.

## After 50 % of Useful Life

Following the running-in period the wear rate reduces to a minimum and the percentage of bronze exposed gradually increases.

## End of Useful Life

After an extended period of operation the wear rate increases as the component approaches the end of its useful life as a self-lubricating bearing. At this stage at least 70 % of the bearing surface will be exposed bronze, and approximately 0,06 mm wear will have occurred.

## Wear of Mating Surfaces

There is no measurable wear of mating surfaces made from recommended materials unless a DU® bearing is operated beyond its useful life or becomes contaminated with abrasive dirt.

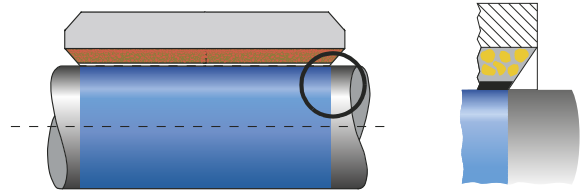

Fig. 6: Running-in

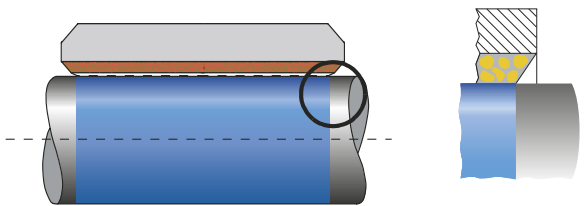

Fig. 7: After 50 % of useful life

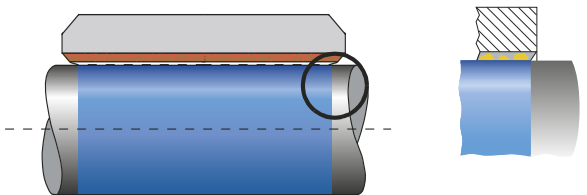

Fig. 8: End of useful life

## 2.3 PHYSICAL, MECHANICAL AND ELECTRICAL PROPERTIES

BEARING PROPERTIES		SYMBOL	UNIT	VALUE		COMMENTS
				DU®	DU-B	
<b>PHYSICAL PROPERTIES</b>						
Thermal conductivity		$\lambda$	W/mK	40	60	after running-in
Coefficient of linear thermal expansion	parallel to surface	$\alpha_1$	$10^{-6}/K$	11	18	measured on strip 1,9 mm thick
	normal to service	$\alpha_2$		30	36	
Operating temperature		$T_{max}$	°C	+280	+280	
		$T_{min}$		-200	-200	
<b>MECHANICAL PROPERTIES</b>						
Compressive yield strength		$\sigma_c$	N/mm <sup>2</sup>	350	300	measured on disc Ø 25 mm x 2,44 mm thick
Maximum load	static	$p_{sta.max}$	N/mm <sup>2</sup>	250	140	
	dynamic	$p_{dyn.max}$		140	140	
<b>ELECTRICAL PROPERTIES</b>						
Surface resistance		$R_{OB}$	$\Omega$	1 - 10	1 - 12	depends on applied pressure and contact area
<b>NUCLEAR RADIATION RESISTANCE</b>						
Maximum thermal neutron dose		$D_{Nth}$	nvt	$2 \times 10^{15}$	$2 \times 10^{15}$	nvt = thermal neutron flux
Maximum gamma ray dose		$D_\gamma$	Gy = J/kg	$10^6$	$10^6$	1 Gray = 1J/kg

Table 2: Properties of DU and DU-B

# 2 Material

## 2.4 CHEMICAL PROPERTIES

The following table provides an indication of the chemical resistance of DU® and DU-B to various chemical media. It is recommended that the chemical resistance is confirmed by testing if possible.

CHEMICAL	%	°C	DU®	DU-B
<b>STRONG ACIDS</b>				
Hydrochloric Acid	5	20	-	-
Nitric Acid	5	20	-	-
Sulfuric Acid	5	20	-	-
<b>WEAK ACIDS</b>				
Acetic Acid	5	20	-	o
Formic Acid	5	20	-	o
<b>BASES</b>				
Ammonia	10	20	o	-
Sodium Hydroxide	5	20	o	o

CHEMICAL	°C	DU®	DU-B
<b>SOLVENTS</b>			
Acetone	20	+	+
Carbon Tetrachloride	20	+	+
<b>LUBRICANTS AND FUELS</b>			
Paraffin	20	+	+
Gasolene	20	+	+
Kerosene	20	+	+
Diesel Fuel	20	+	+
Mineral Oil	70	o	o
HFA-ISO46 High Water Fluid	70	o	o
HFC-Water-Glycol	70	-	-
HFD-Phosphate Ester	70	o	o
Water	20	o	+
Sea Water	20	-	o

Table 3: Chemical Resistance of DU and DU-B

- + Satisfactory: Corrosion damage is unlikely to occur
- o Acceptable: Some corrosion damage may occur but this will not be sufficient to impair either the structural integrity or the tribological performance of the material
- Unsatisfactory: Corrosion damage will occur and is likely to affect either the structural integrity and/or the tribological performance of the material

### Electrochemical Corrosion

DU-B should not be used in conjunction with aluminium housings due to the risk of electrochemical corrosion in the presence of water or moisture.

## 2.5 FRICTIONAL PROPERTIES

DU® bearings show negligible 'stick-slip' and provide smooth sliding between adjacent surfaces. The coefficient of friction of DU® depends upon:

- The specific load  $p$  [N/mm<sup>2</sup>]
- The sliding speed  $U$  [m/s]
- The roughness of the mating running surface  $R_a$  [μm]
- The bearing temperature  $T$  [°C].

A typical relationship is shown in Fig. 9, which can be used as a guide to establish the actual friction under clean, dry conditions after running in.

Exact values may vary by ± 20 % depending on operating conditions.

Before running in, the friction may be up to 50 % higher. With frequent starts and stops, the static coefficient of friction is approximately equal to, or even slightly less than the dynamic coefficient of friction.

After progressively longer periods of dwell under load (e.g. hours or days) the static coefficient of friction on the first movement may be between 1,5 and 3 times greater, particularly before running in. Friction increases at bearing temperatures below 0 °C. Where frictional characteristics are critical to a design they should be established by prototype testing.

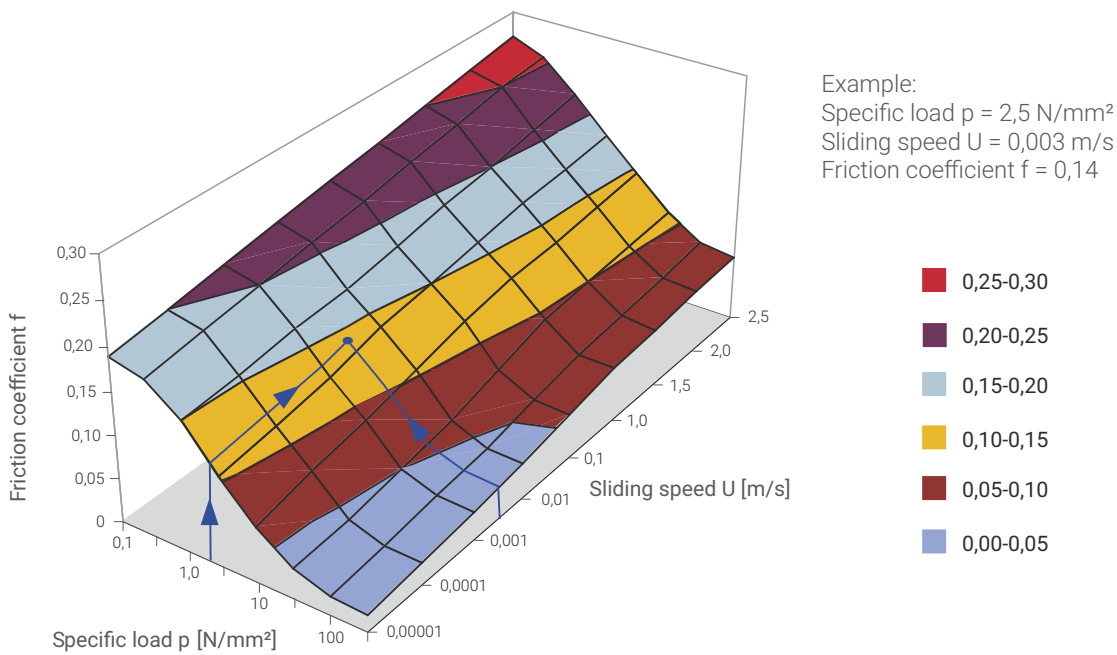

Fig. 9: Variation of friction coefficient  $f$  with specific load  $p$  and sliding speed  $U$  at temperature  $T = 25 \text{ °C}$

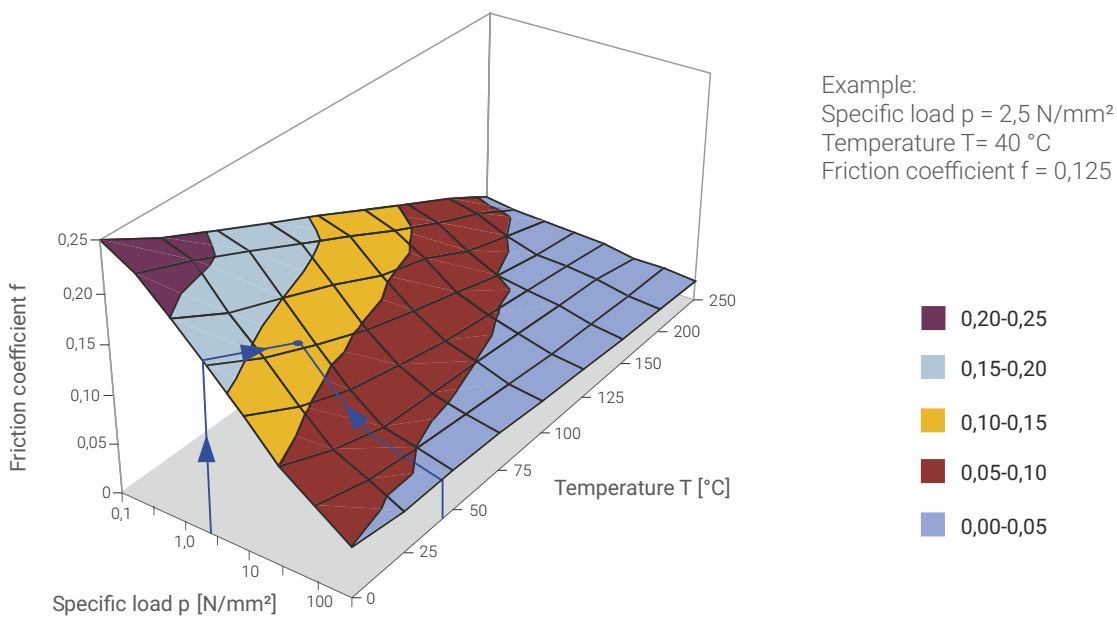

Fig. 10: Variation of friction coefficient  $f$  with specific load  $p$  and temperature  $T$  at sliding speed  $U = 0,01 \text{ m/s}$

# 3 Performance

## 3.1 DESIGN FACTORS

The main parameters when determining the size or calculating the service life for a DU® bearing are:

- Specific Load Limit  $p_{lim}$
- Mating surface material
- pU Factor
- Temperature T
- Mating surface roughness Ra
- Other environmental factors e.g. housing design, dirt, lubrication conditions.

### Calculation

Two design procedures are provided as follows:

- SA bearing service life calculation based on the permitted bearing dimensions
- A calculation of the necessary bearing dimensions based on the required bearing service life

## 3.2 SPECIFIC LOAD $p$

For the purpose of assessing bearing performance the specific load  $p$  is defined as the working load divided by the projected area of the bearing and is expressed in N/mm<sup>2</sup>.

### Cylindrical Bush

$$(3.2.1) \quad p = \frac{F}{D_i \cdot B} \quad [\text{N/mm}^2]$$

### Thrust Washer

$$(3.2.2) \quad p = \frac{4F}{\pi \cdot (D_o^2 - D_i^2)} \quad [\text{N/mm}^2]$$

### Flanged Bush (Axial Loading)

$$(3.2.3) \quad p = \frac{F}{0,04 \cdot (D_f^2 - D_i^2)} \quad [\text{N/mm}^2]$$

### Slideway

$$(3.2.4) \quad p = \frac{F}{L \cdot W} \quad [\text{N/mm}^2]$$

Permanent deformation of the DU® bearing lining may occur at specific loads above 140 N/mm<sup>2</sup> and under these conditions DU® should only be used with slow intermittent movements.

The permissible maximum load on a thrust washer is higher than that on the flange of a flanged bush, and under conditions of high axial loads a thrust washer should be specified.

### 3.3 SPECIFIC LOAD LIMIT $p_{lim}$

The maximum load which can be applied to a DU® bearing can be expressed in terms of the Specific Load Limit, which depends on the type of the loading. It is highest under steady loads. Conditions of dynamic load or oscillating movement which produce fatigue stress in the bearing result in a reduction in the permissible Specific Load Limit.

In general the specific load on a DU® bearing should not exceed the Specific Load Limits given in Table 4.

The values of Specific Load Limit specified in Table 4 assume good alignment between the bearing and mating surface (Fig. 29).

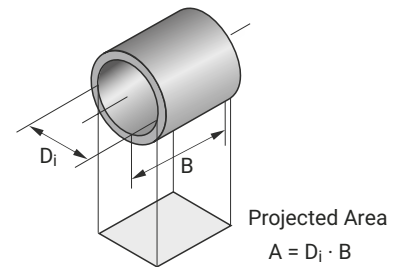

Fig. 11: Projected Area

#### Maximum Specific Load $p_{lim}$

TYPE OF LOADING / $p_{lim}$ [Nmm <sup>2</sup> ]										
Steady load - rotating movement $p_{lim}$ 140										
Steady load - oscillating movement										
$p_{lim}$	140	140	115	95	85	80	60	44	30	20
Number of movement cycles Q	1000	2000	4000	6000	8000	10 <sup>4</sup>	10 <sup>5</sup>	10 <sup>6</sup>	10 <sup>7</sup>	10 <sup>8</sup>
Dynamic load - rotating or oscillating movement										
$p_{lim}$	60	60	50	46	42	40	30	22	15	10
Number of load cycles Q	1000	2000	4000	6000	8000	10 <sup>4</sup>	10 <sup>5</sup>	10 <sup>6</sup>	10 <sup>7</sup>	10 <sup>8</sup>

Table 4: Maximum specific load  $p_{lim}$

### 3.4 SLIDING SPEED U

Speeds in excess of 2.5 m/s sometimes lead to overheating, and a running in procedure may be beneficial. This could consist of a series of short runs progressively increasing in duration from an initial run of a few seconds.

#### Continuous Rotation

##### Cylindrical Bush

$$(3.4.1) \quad U = \frac{D_i \cdot \pi \cdot N}{60 \cdot 10^3} \quad [\text{m/s}]$$

##### Thrust Washer

$$(3.4.2) \quad U = \frac{\frac{D_o + D_i}{2} \cdot \pi \cdot N}{60 \cdot 10^3} \quad [\text{m/s}]$$

#### Oscillating Movement

##### Cylindrical Bush

$$(3.4.3) \quad U = \frac{D_i \cdot \pi}{60 \cdot 10^3} \cdot \frac{4\Phi \cdot N_{osz}}{360} \quad [\text{m/s}]$$

##### Thrust Washer

$$(3.4.4) \quad U = \frac{\frac{D_o + D_i}{2} \cdot \pi}{60 \cdot 10^3} \cdot \frac{4\Phi \cdot N_{osz}}{360} \quad [\text{m/s}]$$

# 3 Performance

## 3.5 pU FACTOR

The useful operating life of a DU® bearing is governed by the pU factor, the product of the specific load  $p$  [N/mm<sup>2</sup>] and the sliding speed  $U$  [m/s].

For thrust washers and flanged bush thrust faces the rubbing velocity at the mean diameter is used.

pU factors up to 3.6 N/mm<sup>2</sup> x m/s can be accommodated for short periods, whilst for continuous rating.

pU factors up to 1.8 N/mm<sup>2</sup> x m/s can be used, depending upon the operating life required.

	DU	UNIT
$p$	140	N/mm <sup>2</sup>
$U$	2,5	m/s
pU continuous	1,8	N/mm <sup>2</sup> · m/s
pU intermittent	3,6	N/mm <sup>2</sup> · m/s

### Calculation of pU Factor

$$(3.5.1) \quad [N/mm^2 \cdot m/s]$$

$$pU = p \cdot U$$

Table 5: Typical data  $p$ ,  $U$  and  $pU$

## 3.6 APPLICATION FACTORS

The following factors influence the bearing performance of DU and must be considered in calculating the required dimension or estimating the bearing life for a particular application.

### Temperature

The useful life of a DU bearing depends upon the operating temperature.

Under dry running conditions frictional heat is generated at the rubbing surface of the bearing dependent on the pU condition. For a given pU factor the operating temperature of the bearing depends upon the temperature of the surrounding environment and the heat dissipation properties of the housing. Intermittent operation affects the heat dissipation from the assembly and hence the operating temperature of the bearing.

The effect of temperature on the operating life of DU bearings is indicated by the factor  $a_T$  shown in Table 6.

MODE OF OPERATION	NATURE OF HOUSING	TEMPERATURE OF BEARING ENVIRONMENT $T_{amb}$ [°C] AND TEMPERATURE APPLICATION FACTOR $a_T$					
		[°C] 25	60	100	150	200	280
<b>Dry continuous operation</b>	Average heat dissipating qualities	1,0	0,8	0,6	0,4	0,2	0,1
<b>Dry continuous operation</b>	Light pressings or isolated housing with poor heat dissipating qualities	0,5	0,4	0,3	0,2	0,1	-
<b>Dry continuous operation</b>	Non-metallic housings with bad heat dissipating qualities	0,3	0,3	0,2	0,1	-	-
<b>Dry intermittent operation</b> (duration less than 2 min, followed by a longer dwell period)	Average heat dissipating qualities	2,0	1,6	1,2	0,8	0,4	0,2
<b>Continuously immersed in water</b>		2,0	1,5	0,6	-	-	-
<b>Alternately immersed in water &amp; dry</b>		0,2	0,1	-	-	-	-
<b>Continuously immersed in non lubricant liquids other than water</b>		1,5	1,2	0,9	0,6	0,3	0,1
<b>Continuously immersed in lubricant</b>		3,0	2,5	2,0	1,5	-	-

Table 6: Temperature application factor  $a_T$



## Mating Surface

The effect of the mating surface material type on the operating life of DU® bearings is indicated by the mating surface factor  $a_M$  and the life correction constant  $a_L$  shown in Table 7.

MATERIAL	$a_M$	$a_L$
<b>Steel and Cast Iron</b>		
Carbon Steel	1	200
Carbon Manganese Steel	1	200
Alloy Steel	1	200
Case Hardened Steel	1	200
Nitrided Steel	1	200
Salt bath nitrocarburised	1	200
Stainless Steel (7-10 % Ni, 17-20 % Cr)	2	200
Sprayed Stainless Steel	1	200
Cast Iron (0,3 $\mu\text{m}$ $R_a$ )	1	200

MATERIAL	$a_M$	$a_L$
<b>Plated Steel with min. Thickness of Plating 0,013 mm</b>		
Cadmium	0,2	600
Hard Chrome	2,0	600
Lead	1,5	600
Nickel	0,2	600
Phosphated	0,2	300
Tin Nickel	1,2	600
Titanium Nitride	1,0	600
Tungsten Carbide Flame Plated	3,0	600
Zinc	0,2	600
<b>Non Ferrous Metals</b>		
Aluminium Alloys	0,4	200
Bronze and Copper Base Alloys	0,1-0,4	200
Hard Anodised Aluminium (0,025 mm thick)	3,0	600

Table 7: Mating surface factor  $a_M$  and life correction constant  $a_L$

### Note:

The factor values given assume a mating surface finish of  $\leq 0.4 \mu\text{m} R_a$

- A ground surface is preferred to fine turned
- Surfaces should be cleaned of abrasive particles after polishing
- Cast iron surfaces should be ground to  $< 0,3 \mu\text{m} R_a$
- The grinding cut should be in the same direction as the bearing motion relative to the shaft

## Bearing Size

The running clearance of a DU® bearing increases with bearing diameter resulting in a proportionally smaller contact area between the shaft and bearing. This reduction in contact area has the effect of increasing the actual unit load and hence pU factor. The bearing size factor (Fig. 13) is used in the design calculations to allow for this effect. The bearing size factor is also applicable to thrust washers, where for other reasons, bearing diameter has an effect on performance.

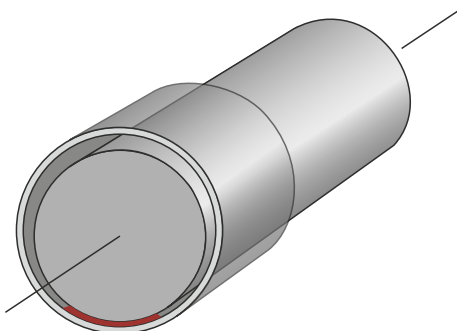

Figure 12: Contact area between bearing and shaft

# 3 Performance

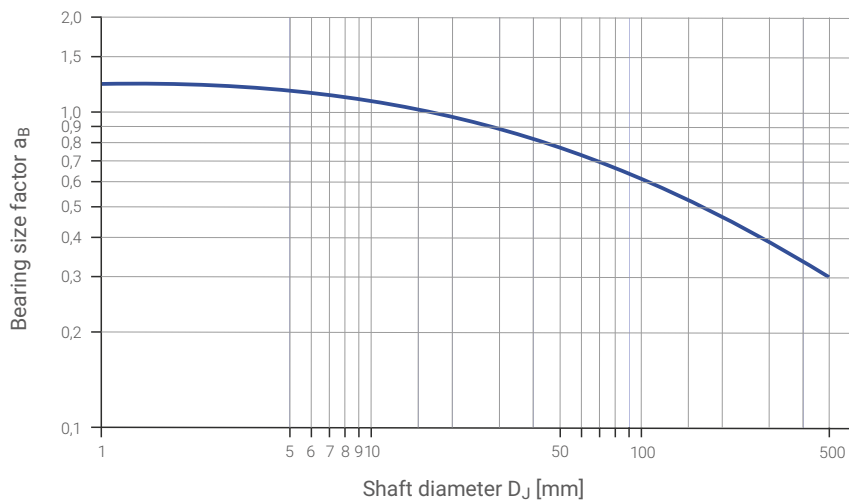

Fig. 13: Bearing size factor  $a_B$

## Bore Burnishing

Burnishing or machining the bore of a DU® bearing results in a reduction in the wear performance. The application factor  $a_C$  given in Table 8 is used in the design calculations to allow for this effect.

DEGREE OF SIZING	APPLICATION FACTOR $a_C$	
<b>BURNISHING</b>		
	0,025 mm	0,8
Excess of burnishing tool diameter over mean bore size	0,038 mm	0,6
	0,050 mm	0,3
<b>BORING</b>		
	0,025 mm	0,6
Depth of cut	0,038 mm	0,3
	0,050 mm	0,1

Table 8: Bore burnishing or machining application factor  $a_C$

## Type of Load

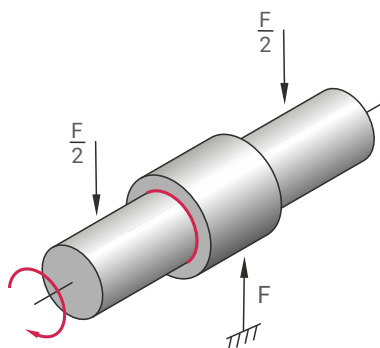

Fig. 14: Steady load, Bush stationary, Shaft rotating

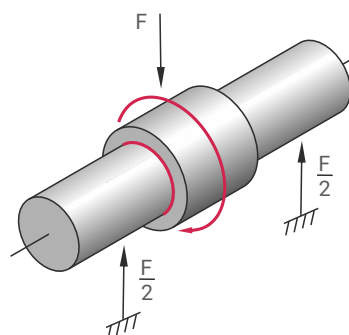

Fig. 15: Rotating load, Shaft stationary, Bush rotating

## 3.7 CALCULATION OF BEARING SIZE

In designing all bearings, the shaft diameter is usually determined by considerations of physical stability or stiffness and the main variable to be determined is the length of the bush or the land width of the thrust washer.

The formulae given below enable designers to calculate the length or width necessary to satisfy both the Specific Load Limit and the pU/Life relationship.

If it is found that the total length exceeds twice the diameter of the shaft, this indicates that the conditions envisaged are too severe for DU® material and consideration should be given to repositioning the bearings in order to reduce the load.

### Calculation for Bushes

Bush Stationary, Shaft Rotating

$$(3.7.1) \quad B = \frac{F \cdot N \cdot (L_H + a_L)}{1,25 \cdot 10^7 \cdot a_T \cdot a_M \cdot a_B} + \frac{F}{p_{lim} \cdot D_i} \quad [\text{mm}]$$

Bush Rotating, Shaft Stationary

$$(3.7.2) \quad B = \frac{F \cdot N \cdot (L_H + a_L)}{2,5 \cdot 10^7 \cdot a_T \cdot a_M \cdot a_B} + \frac{F}{p_{lim} \cdot D_i} \quad [\text{mm}]$$

### Calculation for Thrust Washers

$$(3.7.3) \quad D_o - D_i = \frac{F \cdot N \cdot (L_H + a_L)}{1,25 \cdot 10^7 \cdot a_T \cdot a_M \cdot a_B} + \sqrt{D_i^2 + \frac{1,3 F}{p_{lim}}} - D_i \quad [\text{mm}]$$

### Calculation for Slideways

$$(3.7.4) \quad A = \frac{2,38 \cdot F \cdot U \cdot (L_H + a_L)}{10^3 \cdot a_T \cdot a_M} \cdot \frac{(L + L_S)}{L} + \frac{F}{p_{lim}} \quad [\text{mm}^2]$$

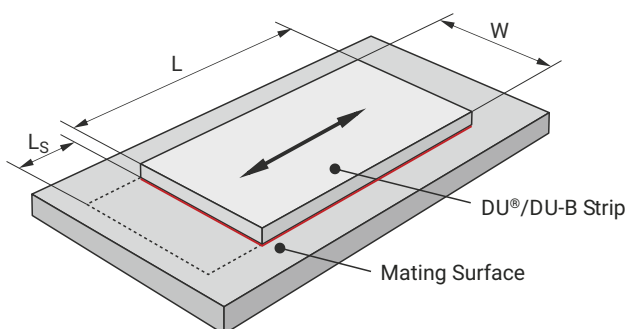

Fig. 16: Slideway

# 3 Performance

## 3.8 CALCULATION OF BEARING SERVICE LIFE

Where the size of a bearing is governed largely by the space available the following calculation can be used to determine whether its useful life will satisfy the requirements. If the calculated life is inadequate, a larger bearing should be considered.

### Specific load $p$

#### Bushes

$$(3.8.1) \quad p = \frac{F}{D_i \cdot B} \quad [\text{N/mm}^2]$$

#### Flanged Bushes

$$(3.8.2) \quad p = \frac{F}{0,04 \cdot (D_{fi}^2 - D_i^2)} \quad [\text{N/mm}^2]$$

#### Thrust Washers

$$(3.8.3) \quad p = \frac{4F}{p \cdot (D_o^2 - D_i^2)} \quad [\text{N/mm}^2]$$

### High Load Factor $a_E$

$$(3.8.4) \quad a_E = \frac{p_{lim} - p}{p_{lim}} \quad [-]$$

$p_{lim}$  see Table 4, Page 15

If  $a_E$  is negative then the bearing is overloaded. Increase the bearing diameter and/or length.

### Modified $pU$ Factor

#### Bushes

$$(3.8.5) \quad pU = \frac{5,25 \cdot 10^{-5} F \cdot N}{a_E \cdot B \cdot a_T \cdot a_M \cdot a_B} \quad [\text{N/mm}^2 \cdot \text{m/s}]$$

#### Flanged Bushes

$$(3.8.6) \quad pU = \frac{6,5 \cdot 10^{-4} F \cdot N}{a_E \cdot (D_{fi} - D_i) \cdot a_T \cdot a_M \cdot a_B} \quad [\text{N/mm}^2 \cdot \text{m/s}]$$

#### Thrust Washers

$$(3.8.7) \quad pU = \frac{3,34 \cdot 10^{-5} F \cdot N}{a_E \cdot (D_o - D_i) \cdot a_T \cdot a_M \cdot a_B} \quad [\text{N/mm}^2 \cdot \text{m/s}]$$

For oscillating movement, calculate the average rotational speed.

$$(3.8.8) \quad N = \frac{4\phi \cdot N_{osz}}{360} \quad [1/\text{min}]$$

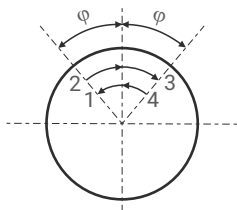

Figure 17: Oscillating cycle  $\phi$



## Estimation of Bearing Life $L_H$

### Bushes (Steady Load)

$$(3.8.9) \quad L_H = \frac{615}{\rho U} - a_L \quad [h]$$

### Bushes (Rotating Load)

$$(3.8.10) \quad L_H = \frac{1230}{\rho U} - a_L \quad [h]$$

### Flanged Bushes (Axial Load)

$$(3.8.11) \quad L_H = \frac{410}{\rho U} - a_L \quad [h]$$

### Thrust Washers

$$(3.8.12) \quad L_H = \frac{410}{\rho U} - a_L \quad [h]$$

## Bore Burnishing

If the DU® bush is bore burnished then this must be allowed for in estimating the bearing life by the application factor  $a_c$  (Table 8, Page 18).

### Estimated Bearing Life

$$(3.8.13) \quad L_H = L_H \cdot a_c \quad [h]$$

## Slideways

### Specific Load Factor

$$(3.8.14) \quad a_{E1} = A - \frac{F}{\rho_{lim}} \quad [-]$$

### Speed Temperature and Material Application Factors

$$(3.8.15) \quad a_{E2} = \frac{420 \cdot a_T \cdot a_M}{F \cdot U} \quad [-]$$

### Relative Contact Area Factor

$$(3.8.16) \quad a_{E3} = \frac{A}{A_M} \quad [-]$$

If negative the bearing is overloaded and the bearing area should be increased.

### Estimated Bearing Life

$$(3.8.17) \quad L_H = a_{E1} \cdot a_{E2} \cdot a_{E3} - a_L \quad [h]$$

Estimated bearing lives greater than 4000 h are subject to error due to inaccuracies in the extrapolation of test data.

$$Z_T = L_H \cdot N_{OSZ} \cdot 60 \quad (\text{for oscillating movements - 3.8.18})$$

$$Z_T = L_H \cdot C \cdot 60 \quad (\text{for dynamic load - 3.8.19})$$

Check that  $Z_T$  is less than total number of cycles  $Q$  for the operating specific load  $p$  (Table 4, Page 15)

For oscillating movements or dynamic load: calculate estimated number of cycles  $Z_T$ .

If  $Z_T < Q$ ,  $L_H$  will be limited by wear after  $Z_T$  cycles.

If  $Z_T > Q$ ,  $L_H$  will be limited by fatigue after  $Z_T$  cycles.

# 3 Performance

## 3.9 CALCULATION OF BEARING

### Cylindrical Bush

Given:			
Load Details	Steady Load Continuous Rotation	Inside Diameter $D_i$	40 mm
		Length B	30 mm
Shaft	Steel Unlubricated at 25°C	Bearing Load F	5.000 N
		Rotational Speed N	50 · 1/min

Calculation Constants and Application Factors	
Specific Load Limit $p_{lim}$	140 N/mm <sup>2</sup> (Table 4, Page 15)
Temperature Application Factor $a_T$	1,0 (Table 6, Page 16)
Material Application Factor $a_M$	1,0 (Table 7, Page 17)
Bearing Size Factor $a_B$	0,85 (Fig. 13, Page 18)
Life Correction Constant $a_L$	200 (Table 7, Page 17)

Calculation	Ref	Value
Specific Load p [N/mm <sup>2</sup> ]	(3.2.1) Page 14	$p = \frac{F}{D_i \cdot B} = \frac{5.000}{40 \cdot 30} = 4,17$
Sliding Speed U [m/s]	(3.4.1) Page 15	$U = \frac{D_i \cdot \pi \cdot N}{60 \cdot 10^3} = \frac{40 \cdot 3,14 \cdot 50}{60 \cdot 10^3} = 0,105$
pU Factor Calculate from Table 5, Page 16	(3.5.1) Page 16	$pU = p \cdot U = 4,17 \cdot 0,105 = 0,438$
High Load Factor $a_E$ [-] must be > 0	(3.8.4) Page 20	$a_E = \frac{p_{lim} - p}{p_{lim}} = \frac{140 - 4,17}{140} = 0,97$
Modified pU Factor [N/mm <sup>2</sup> · m/s]	(3.8.5) Page 20	$pU = \frac{5,25 \cdot 10^{-5} F \cdot N}{a_E \cdot B \cdot a_T \cdot a_M \cdot a_B} = 0,53$
Life $L_H$ [h]	(3.8.9) Page 21	$L_H = \frac{615}{pU} \cdot a_L = \frac{615}{0,53} \cdot 200 = 960$

### Cylindrical Bush

Given:			
Load Details	Steady Load Continuous Rotation	Inside Diameter $D_i$	30 mm
		Length B	30 mm
Shaft	Steel Unlubricated at 25°C	Bearing Load F	25.000 N
		Rotational Speed N	15 · 1/min

Calculation Constants and Application Factors	
Specific Load Limit $p_{lim}$	60 N/mm <sup>2</sup> (Table 4, Page 15)
Temperature Application Factor $a_T$	1,0 (Table 6, Page 16)
Material Application Factor $a_M$	1,0 (Table 7, Page 17)
Bearing Size Factor $a_B$	1,0 (Fig. 13, Page 18)
Life Correction Constant $a_L$	200 (Table 7, Page 17)

Calculation	Ref	Value
Specific Load p [N/mm <sup>2</sup> ]	(3.2.1) Page 14	$p = \frac{F}{D_i \cdot B} = \frac{25.000}{40 \cdot 30} = 20,83$
Sliding Speed U [m/s]	(3.4.1) Page 15	$U = \frac{D_i \cdot \pi \cdot N}{60 \cdot 10^3} = \frac{30 \cdot 3,14 \cdot 15}{60 \cdot 10^3} = 0,024$
pU Factor Calculate from Table 5, Page 16	(3.5.1) Page 16	$pU = p \cdot U = 27,78 \cdot 0,024 = 0,669$
High Load Factor $a_E$ [-] must be > 0	(3.8.4) Page 20	$a_E = \frac{p_{lim} - p}{p_{lim}} = \frac{60 - 27,78}{60} = 0,54$
Modified pU Factor [N/mm <sup>2</sup> · m/s]	(3.8.5) Page 20	$pU = \frac{5,25 \cdot 10^{-5} F \cdot N}{a_E \cdot B \cdot a_T \cdot a_M \cdot a_B} = 1,23$
Life $L_H$ [h]	(3.8.9) Page 21	$L_H = \frac{615}{pU} \cdot a_L = \frac{615}{1,23} \cdot 200 = 300$
Calculate Total Load Cycles	Table 4 Page 15	$Z_T = 300 \cdot 60 \cdot 60 = 1,08 \cdot 10^6$
Q for 27,78 N/mm <sup>2</sup> = bearing will fatigue after 10 <sup>5</sup> cycles (= 28h)		

## Cylindrical Bush

Given:		
Load Details	Steady Load Continuous Rotation	Inside Diameter $D_i$ 50 mm Length B 50 mm
Shaft	Steel Unlubricated at 100°C	Bearing Load F 10.000 N Rotational Speed N 50 · 1/min

Calculation Constants and Application Factors	
Specific Load Limit $p_{lim}$	60 N/mm <sup>2</sup> (Table 4, Page 15)
Temperature Application Factor $a_T$	0,6 (Table 6, Page 16)
Material Application Factor $a_M$	1,0 (Table 7, Page 17)
Bearing Size Factor $a_B$	0,78 (Fig. 13, Page 18)
Life Correction Constant $a_L$	200 (Table 7, Page 17)

Calculation	Ref	Value
Specific Load $p$ [N/mm <sup>2</sup> ]	(3.2.1) Page 14	$p = \frac{F}{D_i \cdot B} = \frac{10.000}{50 \cdot 50} = 4,0$
Sliding Speed $U$ [m/s]	(3.4.1) Page 15	$U = \frac{D_i \cdot \pi \cdot N}{60 \cdot 10^3} = \frac{50 \cdot 3,14 \cdot 50}{60 \cdot 10^3} = 0,131$
pU Factor Calculate from Table 5, Page 16	(3.5.1) Page 16	$pU = p \cdot U = 4,0 \cdot 0,131 = 0,542$
High Load Factor $a_E$ [-] must be > 0	(3.8.4) Page 20	$a_E = \frac{p_{lim} - p}{p_{lim}} = \frac{60 - 4,17}{60} = 0,93$
Modified pU Factor [N/mm <sup>2</sup> · m/s]	(3.8.5) Page 20	$pU = \frac{5,25 \cdot 10^{-5} F \cdot N}{a_E \cdot B \cdot a_T \cdot a_M \cdot a_B} = 1,20$
Life $L_H$ [h]	(3.8.9) Page 21	$L_H = \frac{1.230}{pU} \cdot a_L = \frac{1.230}{1,20} \cdot 200 = 825$

## Cylindrical Bush

Given:		
Load Details	Steady Load Oscillating Movement	Inside Diameter $D_i$ 45 mm Length B 40 mm
Shaft	Stainless Steel Unlubricated at 25°C Continuous Operation	Bearing Load F 40.000 N Frequency C 150 Amplitudes $\phi$ 20°

Calculation Constants and Application Factors	
Specific Load Limit $p_{lim}$	140 N/mm <sup>2</sup> (Table 4, Page 15)
Temperature Application Factor $a_T$	1,0 (Table 6, Page 16)
Material Application Factor $a_M$	2,0 (Table 7, Page 17)
Bearing Size Factor $a_B$	0,81 (Fig. 13, Page 18)
Life Correction Constant $a_L$	200 (Table 7, Page 17)

Calculation	Ref	Value
Specific Load $p$ [N/mm <sup>2</sup> ]	(3.2.1) Page 14	$p = \frac{F}{D_i \cdot B} = \frac{40.000}{45 \cdot 40} = 22,22$
Sliding Speed $U$ [m/s]	(3.4.1) Page 15	$U = \frac{D_i \cdot \pi \cdot N}{60 \cdot 10^3} = \frac{45 \cdot 3,14 \cdot 33,33}{60 \cdot 10^3} = 0,078$
Average Speed $N$ [1/min]	(3.8.8) Page 20	$N = \frac{4\phi \cdot N_{osz}}{360} = \frac{4 \cdot 20 \cdot 150}{360} = 33,33$
pU Factor Calculate from Table 5, Page 16	(3.5.1) Page 16	$pU = p \cdot U = 22,22 \cdot 0,078 = 1,733$
High Load Factor $a_E$ [-] must be > 0	(3.8.4) Page 20	$a_E = \frac{p_{lim} - p}{p_{lim}} = \frac{140 - 22,22}{140} = 0,84$
Modified pU Factor [N/mm <sup>2</sup> · m/s]	(3.8.5) Page 20	$pU = \frac{5,25 \cdot 10^{-5} F \cdot N}{a_E \cdot B \cdot a_T \cdot a_M \cdot a_B} = 1,29$
Life $L_H$ [h]	(3.8.9) Page 21	$L_H = \frac{615}{pU} \cdot a_L = \frac{615}{1,29} \cdot 200 = 277$
Calculate Total Load Cycles	Table 4 Page 15	$Z_T = 277 \cdot 150 \cdot 60 = 2,5 \cdot 10^6$
Q for 22,22 N/mm <sup>2</sup> = 10 <sup>8</sup> bearing o.k.!		

## Thrust Washer

Given:		
Load Details	Axial Load Continuous Rotation	Outside Diameter $D_o$ 62 mm Inside Diameter $D_i$ 38 mm
Shaft	Steel Unlubricated at 25°C	Bearing Load F 6.500 N Rotational Speed N 60 · 1/min

Calculation Constants and Application Factors	
Specific Load Limit $p_{lim}$	140 N/mm <sup>2</sup> (Table 4, Page 15)
Temperature Application Factor $a_T$	1,0 (Table 6, Page 16)
Material Application Factor $a_M$	1,0 (Table 7, Page 17)
Bearing Size Factor $a_B$	0,85 (Fig. 13, Page 18)
Life Correction Constant $a_L$	200 (Table 7, Page 17)

Calculation	Ref	Value
Specific Load $p$ [N/mm <sup>2</sup> ]	(3.8.3) Page 20	$p = \frac{4 \cdot 6.500}{3,14 \cdot (62^2 - 38^2)} = 3,45$
Sliding Speed $U$ [m/s]	(3.4.2) Page 15	$U = \frac{(62 + 38) \cdot 3,14 \cdot 60}{60 \cdot 10^3} = 0,157$
pU Factor Calculate from Table 5, Page 16	(3.5.1) Page 16	$pU = p \cdot U = 3,45 \cdot 0,157 = 0,541$
High Load Factor $a_E$ [-] must be > 0	(3.8.4) Page 20	$a_E = \frac{p_{lim} - p}{p_{lim}} = \frac{140 - 3,45}{140} = 0,98$
Modified pU Factor [N/mm <sup>2</sup> · m/s]	(3.8.7) Page 20	$pU = \frac{3,34 \cdot 10^{-5} \cdot 6.500 \cdot 60}{0,87 \cdot (62 - 38) \cdot 1 \cdot 1 \cdot 0,85} = 0,56$
Life $L_H$ [h]	(3.8.12) Page 21	$L_H = \frac{410}{pU} \cdot a_L = \frac{410}{0,65} \cdot 200 = 431$

## Flanged Bush

Given:		
Load Details	Axial Load Continuous Rotation	Flange Outside $\phi D_{fl}$ 23 mm Inside Diameter $D_i$ 15 mm
Shaft	Steel Unlubricated at 25°C	Bearing Load F 250 N Rotational Speed N 25 · 1/min

Calculation Constants and Application Factors	
Specific Load Limit $p_{lim}$	140 N/mm <sup>2</sup> (Table 4, Page 15)
Temperature Application Factor $a_T$	1,0 (Table 6, Page 16)
Material Application Factor $a_M$	1,0 (Table 7, Page 17)
Bearing Size Factor $a_B$	1,0 (Fig. 13, Page 18)
Life Correction Constant $a_L$	200 (Table 7, Page 17)

Calculation	Ref	Value
Specific Load $p$ [N/mm <sup>2</sup> ]	(3.2.2) Page 14	$p = \frac{250}{0,04 \cdot (23^2 - 15^2)} = 20,55$
Sliding Speed $U$ [m/s]	(3.4.2) Page 15	$U = \frac{(23 + 15) \cdot 3,14 \cdot 25}{60 \cdot 10^3} = 0,025$
pU Factor Calculate from Table 5, Page 16	(3.5.1) Page 16	$pU = p \cdot U = 20,55 \cdot 0,025 = 0,513$
High Load Factor $a_E$ [-] must be > 0	(3.8.4) Page 20	$a_E = \frac{p_{lim} - p}{p_{lim}} = \frac{140 - 20,55}{140} = 0,85$
Modified pU Factor [N/mm <sup>2</sup> · m/s]	(3.8.6) Page 20	$pU = \frac{6,5 \cdot 10^{-5} \cdot 250 \cdot 50}{0,85 \cdot (23 - 15) \cdot 1 \cdot 1 \cdot 1} = 0,59$
Life $L_H$ [h]	(3.8.11) Page 21	$L_H = \frac{410}{pU} \cdot a_L = \frac{410}{0,59} \cdot 200 = 495$

# 4 Lubrication

Although DU® was developed as a dry self lubricating bearing material, DU® also provides excellent performance in lubricated applications.

The following sections describe the basics of lubrication and provide guidance on the application of DU in such environments.

## 4.1 LUBRICANTS

DU® can be used with most fluids including:

- water
- lubricating oils
- engine oil
- turbine oil
- hydraulic fluid
- solvent
- refrigerants

In general, the fluid will be acceptable if it does not chemically attack the PTFE/lead overlay or the porous

bronze interlayer. Where there is doubt about the suitability of a fluid, a simple test is to submerge a sample of DU® material in the fluid for two to three weeks at 15-20 °C above the operating temperature.

The following will usually indicate that the fluid is not suitable for use with DU®:

- A significant change in the thickness of the DU® material,
- a visible change in the bearing surface other than some discolouration or staining,
- a visible change in the microstructure of the bronze interlayer.

## 4.2 TRIBOLOGY

There are three modes of lubricated bearing operation which relate to the thickness of the developed lubricant film between the bearing and the mating surface.

These three modes of operation depend upon:

- Bearing dimensions
- Clearance

- Load
- Speed
- Lubricant Viscosity
- Lubricant Flow

### Hydrodynamic lubrication

#### Characterised by:

- Complete separation of the shaft from the bearing by the lubricant film
- Very low friction and no wear of the bearing or shaft since there is no contact.
- Coefficients of friction of 0,001 to 0,01

Hydrodynamic conditions occur when:

$$(4.2.1) \quad p \leq \frac{U \cdot \eta}{7,5} \cdot \frac{B}{D_i} \quad [\text{N/mm}^2]$$

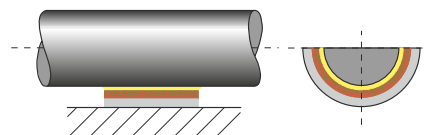

Figure 18: Hydrodynamic lubrication



## Mixed Film Lubrication

### Characterised by:

- Combination of hydrodynamic and boundary lubrication.
- Part of the load is carried by localised areas of self pressurised lubricant and the remainder supported by boundary lubrication.
- Friction and wear depend upon the degree of hydrodynamic support developed.

- DU® provides low friction and high wear resistance to support the boundary lubricated element of the load.

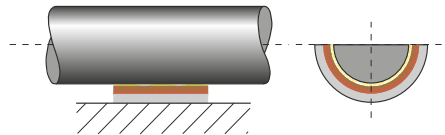

Figure 19: Mixed film lubrication

## Boundary Lubrication

### Characterised by:

- Rubbing of the shaft against the bearing with virtually no lubricant separating the two surfaces.
- Bearing material selection is critical to performance
- Shaft wear is likely due to contact between bearing and shaft.
- The excellent self lubricating properties of DU® material minimises wear under these conditions.

- The coefficient of friction with DU® is typically 0,02 to 0,06 under boundary lubrication conditions.

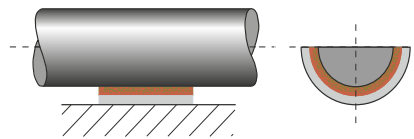

Figure 20: Boundary lubrication

## 4.3 CHARACTERISTICS OF LUBRICATED DU® BEARINGS

DU® is particularly effective in the most demanding of lubricated applications where full hydrodynamic operation cannot be maintained, for example:

### - High load conditions

In highly loaded applications operating under boundary or mixed film conditions DU® shows excellent wear resistance and low friction.

### - Start up and shut down under load

With insufficient speed to generate a hydrodynamic film the bearing will operate under boundary or mixed film conditions. DU® minimises wear and requires less start up torque than conventional metallic bearings.

### - Sparse lubrication

Many applications require the bearing to operate with less than the ideal lubricant supply, typically with splash or mist lubrication only. DU® provides excellent self lubricating properties.

### - Dry operation after running in water

If a DU® bearing is required to run dry after running in water under non hydrodynamic conditions then the wear resistance will be substantially reduced due to an increased amount of bedding in wear.

# 4 Lubrication

## 4.4 DESIGN GUIDANCE FOR LUBRICATED APPLICATIONS

Fig. 21 shows the three lubrication regimes discussed above. In order to use Fig. 21, using the formula on page 14 and page 15:

- Calculate the specific load  $p$ ,
- Calculate the shaft surface speed  $U$ .

Using the viscosity temperature relationships presented in Table 9.

- Determine the lubricant viscosity in centipoise, of the lubricant.

If the operating temperature of the fluid is unknown, a provisional temperature of 25 °C above ambient can be used.

### Area 1

The bearing will operate with boundary lubrication and  $pU$  factor will be the major determinant of bearing life. The  $DU^{\circ}$  bearing performance can be calculated using the method given in Section 3, although the result will probably underestimate the bearing life

### Area 2

The bearing will operate with mixed film lubrication and the  $pU$  factor is no longer a significant parameter in determining the bearing life. The  $DU^{\circ}$  bearing performance will depend upon the nature of the fluid and the actual service conditions.

### Area 3

The bearing will operate with hydrodynamic lubrication. The bearing wear will be determined only by the cleanliness of the lubricant and the frequency of start up and shut down.

### Area 4

These are the most demanding operating conditions. The bearing is operated under either high speed or high bearing load to viscosity ratio, or a combination of both. These conditions may cause:

- excessive operating temperature and/or
- high wear rate.

The bearing performance may be improved by adding one or more grooves to the bearing and a shaft surface finish  $<0,05 \mu\text{m Ra}$ .

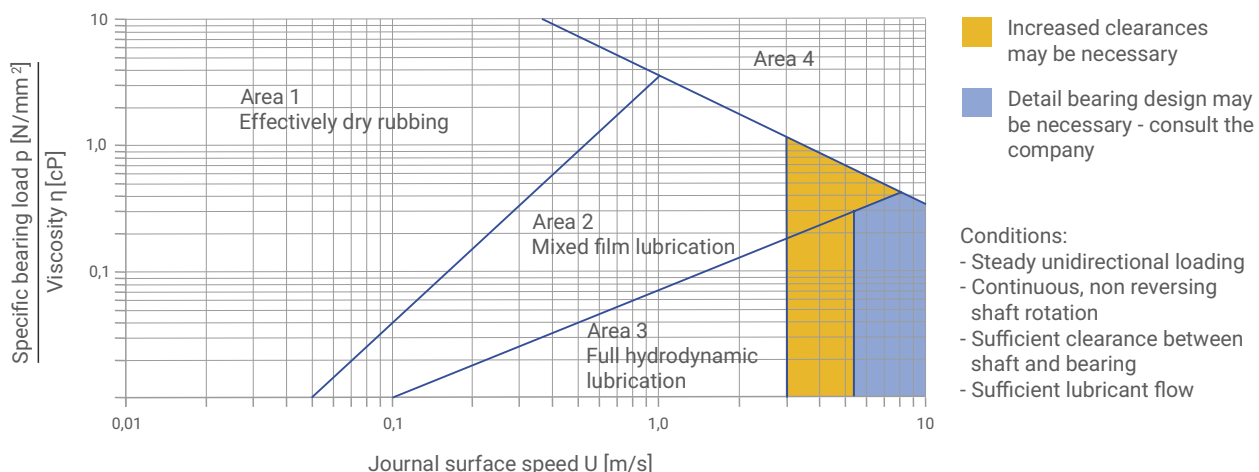

Fig. 21: Design guide for lubricated application

Temperature [°C]	VISCOSITY $\eta$ [cP]														
	0	10	20	30	40	50	60	70	80	90	100	110	120	130	140
Lubricant															
ISO VG 32	310	146	77	44	27	18	13	9,3	7,0	5,5	4,4	3,6	3,0	2,5	2,2
ISO VG 46	570	247	121	67	40	25	17	12	9,0	6,9	5,4	4,4	3,6	3,0	2,6
ISO VG 68	940	395	190	102	59	37	24	17	12	9,3	7,2	5,8	4,7	3,9	3,3
ISO VG 100	2110	780	335	164	89	52	33	22	15	11,3	8,6	6,7	5,3	4,3	3,6
ISO VG 150	3600	1290	540	255	134	77	48	31	21	15	11	8,8	7,0	5,6	4,6
Diesel oil	4,6	4,0	3,4	3,0	2,6	2,3	2,0	1,7	1,4	1,1	0,95				
Petrol	0,6	0,56	0,52	0,48	0,44	0,40	0,36	0,33	0,31						
Kerosene	2,0	1,7	1,5	1,3	1,1	0,95	0,85	0,75	0,65	0,60	0,55				
Water	1,79	1,30	1,0	0,84	0,69	0,55	0,48	0,41	0,34	0,32	0,28				

Table 9: Viscosity data

## 4.5 CLEARANCES FOR LUBRICATED OPERATION

The recommended shaft and housing diameters given for standard DU® bushes will provide sufficient clearance for applications operating with boundary lubrication.

For bearings operating with mixed film or hydrodynamic lubrication it may be necessary to improve the fluid flow through the bearing by reducing the recommended shaft diameter by approximately 0.1 %, particularly when the shaft surface speed exceeds 2,5 m/s.

## 4.6 MATING SURFACE FINISH FOR LUBRICATED OPERATION

- $R_a \leq 0,4 \mu\text{m}$  boundary lubrication
- $R_a = 0,1 - 0,2 \mu\text{m}$  mixed film or hydrodynamic conditions
- $R_a \leq 0,05 \mu\text{m}$  for the most demanding operating conditions

## 4.7 GROOVING FOR LUBRICATED OPERATION

In demanding applications an axial oil groove will improve the performance of DU®. Fig. 22 shows the recommended form and location of a single groove with respect to the applied load and the bearing split. GGB can manufacture special DU® bearings with embossed or milled grooves on request.

## 4.8 GREASE LUBRICATION

DU® is not generally recommended for use with grease lubrication. In particular the following must be avoided:

- Dynamic loads - which can result in erosion of the PTFE/lead bearing surface.
- Greases with EP additives or fillers such as graphite or  $\text{MoS}_2$  which can cause rapid wear of DU®.

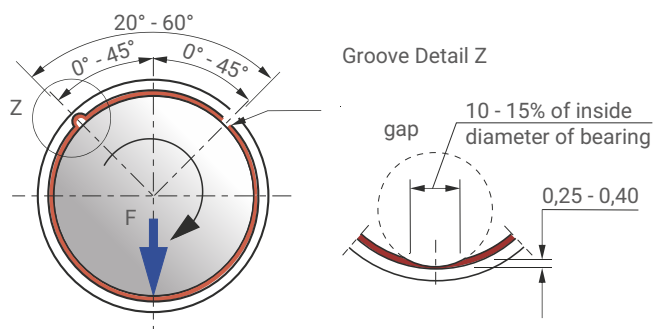

Fig. 22: Location of oil holes and grooves

# 5 Bearing Assembly

## Dimensions and Tolerances

DU® bushes are prefinished in the bore, and except in very exceptional circumstances, must not be burnished, broached or otherwise modified. It is essential that the correct running clearance is used and that both the diameter of the shaft and the bore of the housing are finished to the limits given in the tables. Under dry running conditions any increase in the clearances given will result in a proportional reduction in performance.

If the bearing housing is unusually flexible the bush will not close in by the calculated amount and the running clearance will be more than the optimum. In these circumstances the housing should be bored slightly undersize or the journal diameter increased, the correct size being determined by experiment.

Where free running is essential, or where light loads (less than 0,1 N/mm<sup>2</sup>) prevail and the available torque is low, increased clearance is required and it is recommended that the shaft size quoted in the table be reduced by 0.025 mm.

## 5.1 ALLOWANCE FOR THERMAL EXPANSION

For operation in high temperature environments the clearance should be increased by the amounts indicated by Fig. 23 to compensate for the inward thermal expansion of the bearing lining.

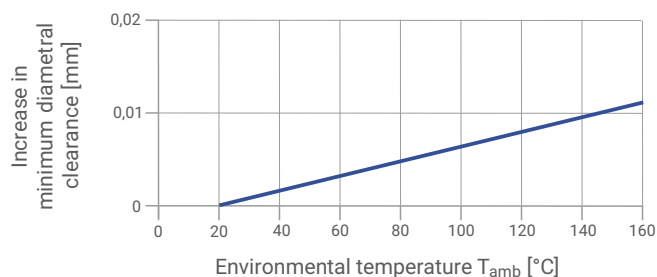

Fig. 23: Increase in diametral clearance

If the housing is non-ferrous then the bore should be reduced by the amounts given in Table 10, in order to give an increased interference fit to the bush, with a similar reduction in the journal diameter additional to that indicated by Fig. 23.

HOUSING MATERIAL	REDUCTION IN HOUSING DIAMETER PER 100°C RISE	REDUCTION IN SHAFT DIAMETER PER 100°C RISE
Aluminium alloys	0,1 %	0,1 % + values from Fig. 23
Copper base alloys	0,05 %	0,05 % + values from Fig. 23
Steel and cast iron	–	values from Fig. 23
Zinc base alloys	0,15 %	0,15 % + values from Fig. 23

Table 10: Allowance for high temperature

## 5.2 TOLERANCES FOR MINIMUM CLEARANCE

Where it is required to keep the variation of assembled clearance to a minimum, closer tolerances can be specified towards the upper end of the journal tolerance and the lower end of the housing tolerance. If housings to H6 tolerance are used, then the journals should be finished to the following limits. The sizes in Table 11 give the following nominal clearance range.

$D_i$	$D_j$
< 25 mm	-0,019 to -0,029
> 25 mm < 50 mm	-0,021 to -0,035

Table 11: Shaft tolerances for use with H6 housings

$D_i$	$D_j$
10 mm	0,005 to 0,078
50 mm	0,005 to 0,130

Table 12: Clearance vs bearing diameter

## Sizing

The burnishing or fine boring of the bore of an assembled DU® bush in order to achieve a smaller clearance tolerance is only permissible if a substantial reduction in performance is acceptable. Fig. 24 shows a recommended burnishing tool for the sizing of DU® bushes.

The coining section of the burnishing tool should be case hardened (case depth 0,6 - 1,2 mm, HRC 60±2) and polished ( $R_z \approx 1 \mu\text{m}$ ).

Note: Ball burnishing of DU® bushes is not recommended.

The values given in Table 13 indicate the dimensions of the burnishing tool required to give specific increases in the bearing bore diameter.

Exact values must be determined by test.

The reduction in bearing performance as a result of burnishing is allowed for in the bearing life calculation by the application factor  $a_C$  (Table 8, page 18).

ASSEMBLED BUSH INSIDE Ø	REQUIRED BUSH INSIDE Ø	REQUIRED BURNISHING TOOL Ø $D_C$
$D_{i,a}$	$D_{i,a} + 0,025$	$D_{i,a} + 0,06$
$D_{i,a}$	$D_{i,a} + 0,038$	$D_{i,a} + 0,08$
$D_{i,a}$	$D_{i,a} + 0,050$	$D_{i,a} + 0,1$

Table 13: Burnishing tool tolerances

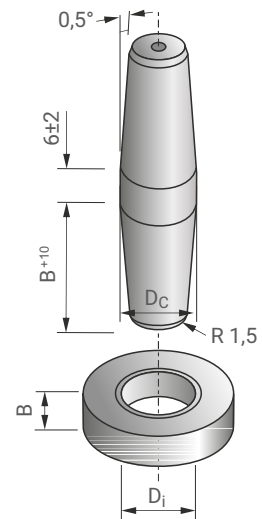

Fig. 24: Burnishing tool

## 5.3 COUNTERFACE DESIGN

The suitability of mating surface materials and recommendations of mating surface finish for use with DU® are discussed in detail on page 17.

DU® is normally used in conjunction with ferrous journals and thrust faces, but in damp or corrosive surroundings, particularly without the protection of oil or grease, stainless steel, hard chromium plated mild steel, or hard anodised aluminium is recommended. When plated mating surfaces are specified the plating should possess adequate strength and adhesion, particularly if the bearing is to operate with high fluctuating loads.

The shaft or thrust collar used in conjunction with the DU® bush or thrust washer must extend beyond the bearing surface in order to avoid cutting into it. The mating surface must also be free from grooves or flats, the end of the shaft should be given a lead-in chamfer and all sharp edges or projections which may damage the soft overlay of the DU® must be removed.

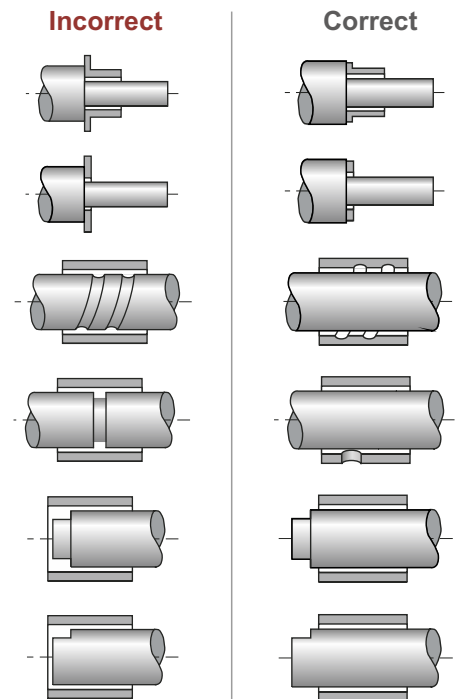

Fig. 25: Counterface Design

# 5 Bearing Assembly

## 5.4 INSTALLATION

### Fitting of Cylindrical Bushes

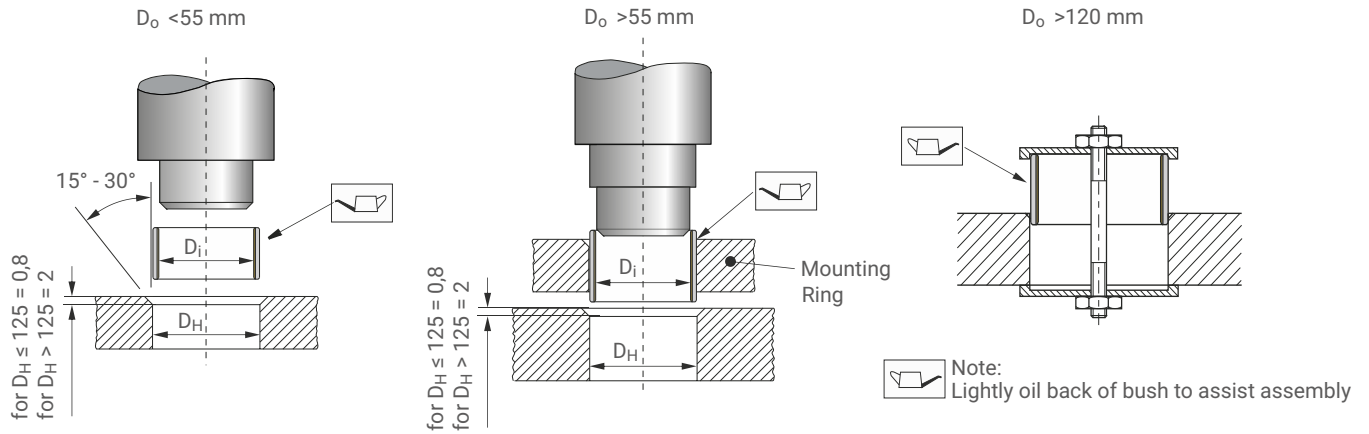

Fig. 26: Fitting of cylindrical bushes

### Fitting of Flanged Bushes

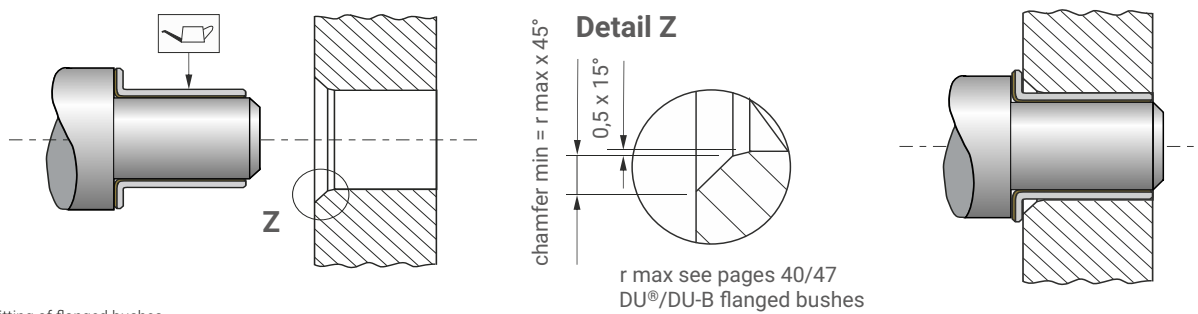

Fig. 27: Fitting of flanged bushes

### Insertion Forces

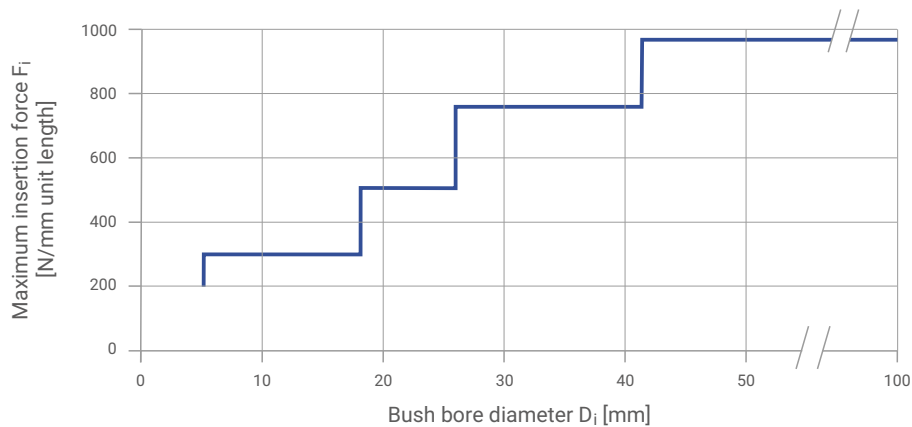

Fig. 28: Maximum Insertion Force  $F_i$

## Alignment

Accurate alignment is an important consideration for all bearing assemblies, but is particularly so for dry bearings because there is no lubricant to spread the load. With DU® bearings misalignment over the length of a bush (or pair of bushes), or over the diameter of a thrust washer should not exceed 0,020 mm as illustrated in Fig. 29.

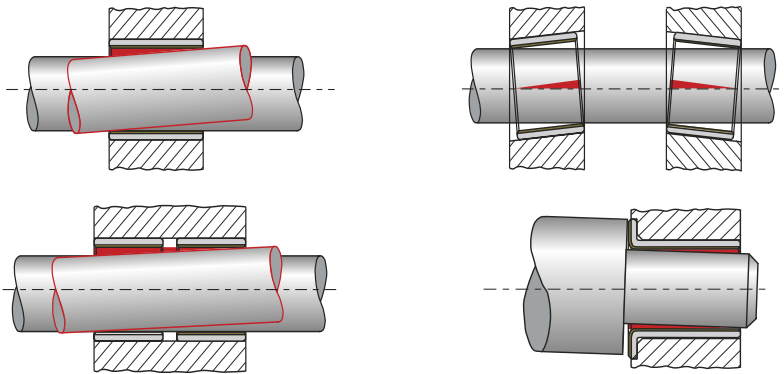

Fig. 29: Alignment

## Sealing

While DU® can tolerate the ingress of some contaminant materials into the bearing without loss of performance, where there is the possibility of highly abrasive material entering the bearing, a suitable sealing arrangement, as illustrated in Fig. 30 should be provided.

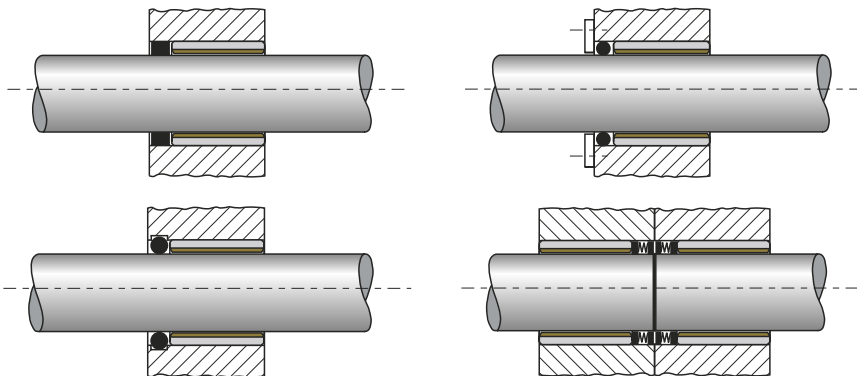

Fig. 30: Recommended sealing arrangements

## 5.5 AXIAL LOCATION

Where axial location is necessary, it is advisable to fit DU® thrust washers in conjunction with DU® bushes, even when the axial loads are low.

### Fitting of Thrust Washers

DU® thrust washers should be located in a recess as shown in Fig. 31. The recess diameter should be 0.125 mm larger than the washer diameter and the depth as given in the product tables. If a recess is not possible one of the following methods may be used:

- Two dowel pins
- Two screws
- Adhesive
- Soldering

# 5 Bearing Assembly

## Important Note

- Ensure the washer ID does not touch the shaft after assembly
- Ensure that the washer is mounted with the steel backing to the housing
- Dowels pins should be recessed 0,25 mm below the bearing surface
- Screws should be countersunk 0,25 mm below the bearing surface
- DU® must not be heated above 320 °C
- Contact adhesive manufacturers for guidance selection of suitable adhesives
- Protect the bearing surface to prevent contact with adhesive

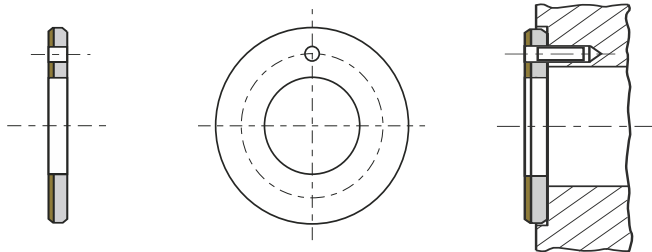

Fig. 31: Installation of Thrust-Washer

## Grooves for Wear Debris Removal

Tests with thrust washers have demonstrated that for optimum dry wear performance at specific loads in excess of 35 N/mm<sup>2</sup>, four wear debris removal grooves should be machined in the bearing surface as shown in Fig. 32.

Grooves in bushes have not been found to be beneficial in this respect.

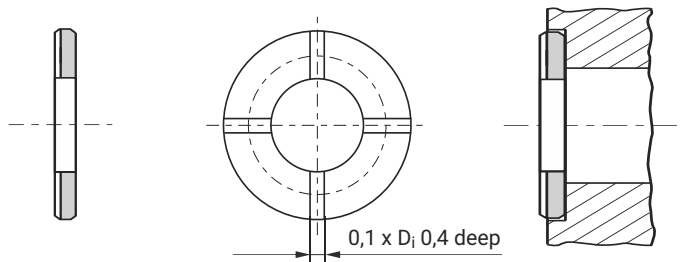

Fig. 32: Debris removal Grooves

## Slideways

DU® strip material for use as slideway bearings should be installed using one of the following methods:

- Countersunk screws
- Adhesives
- Mechanical location as shown in Fig. 33

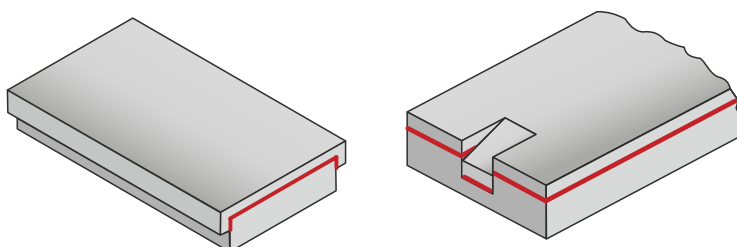

Fig. 33: Mechanical location of DU slideplates



# 6 Modification

## 6.1 CUTTING AND MACHINING

The modification of DU® bearing components requires no special procedures. In general it is more satisfactory to perform machining or drilling operations from the PTFE side in order to avoid burrs. When cutting is done from the steel side, the minimum cutting pressure should be used and care taken to ensure that any steel or bronze particles protruding into the remaining bearing material, and all burrs, are removed.

### Drilling Oil Holes

Bushes should be adequately supported during the drilling operation to ensure that no distortion is caused by the drilling pressure.

### Cutting Strip Material

DU® strip material may be cut to size by any one of the following methods.

Care must be taken to protect the bearing surface from damage and to ensure that no deformation of the strip occurs:

- Using side and face cutter, or slitting saw, with the strip held flat and securely on a horizontal milling machine.

- Cropping
- Guillotine (For widths less than 90 mm only)
- Water-jet cutting
- Laser cutting (see Health Warning)

## 6.2 ELECTROPLATING

### DU® Components

In order to provide some protection in mildly corrosive environments the steel back and end faces of standard range DU® bearings are tin flashed.

If exposed to corrosive liquids further protection should be provided and in very corrosive conditions DU-B should be considered.

DU® can be electroplated with most of the conventional electroplating metals including the following:

- zinc ISO 2081-2
- cadmium ISO 2081-2
- nickel ISO 1456-8
- hard chromium ISO 1456-8

For the harder materials if the specified plating thickness exceeds approximately 5 µm then the housing diameter should be increased by twice the plating thickness in order to maintain the correct assembled bearing bore size.

With light deposits of materials such as cadmium, no special precautions are necessary. Harder materials such as nickel however, may strike through the PTFE/lead surface layer of DU® and it is advisable to use an appropriate method of masking the bearing surface.

Where electrolytic attack is possible tests should be conducted to ensure that all the materials in the bearing environment are mutually compatible.

### Mating Surfaces

DU® can be used against some plated materials as indicated on page 17.

Care should be taken to ensure that the recommended shaft sizes and surface finish are achieved after the plating process.

# 7 Standard Products

## 7.1 DU® CYLINDRICAL BUSHES

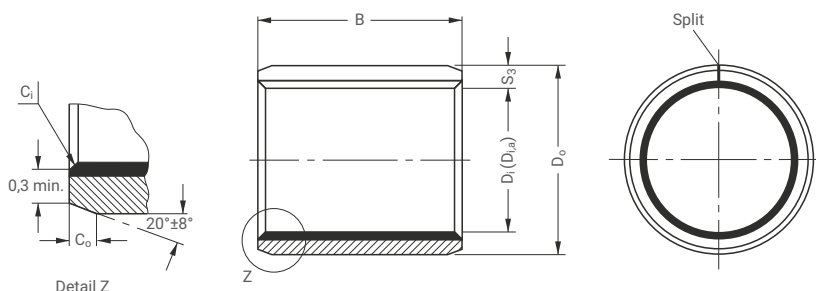

Dimensions and Tolerances according to ISO 3547 and GGB-Specifications

### Outside C<sub>o</sub> and Inside C<sub>i</sub> Chamfers

WALL THICKNESS S <sub>3</sub>	C <sub>o</sub> (a)		C <sub>i</sub> (b)
	MACHINED	ROLLED	
0,75	0,5 ± 0,3	0,5 ± 0,3	-0,1 to -0,4
1	0,6 ± 0,4	0,6 ± 0,4	-0,1 to -0,5
1,5	0,6 ± 0,4	0,6 ± 0,4	-0,1 to -0,7

WALL THICKNESS S <sub>3</sub>	C <sub>o</sub> (a)		C <sub>i</sub> (b)
	MACHINED	ROLLED	
2	1,2 ± 0,4	1,0 ± 0,4	-0,1 to -0,7
2,5	1,8 ± 0,6	1,2 ± 0,4	-0,2 to -1,0

(a) = chamfer C<sub>o</sub> machined or rolled at the opinion of the manufacturer

(b) = C<sub>i</sub> can be a radius or a chamfer in accordance with ISO 13715

PART NO.	NOMINAL DIAMETER		WALL THICKNESS S <sub>3</sub> max. min.	WIDTH B max. min.	SHAFT Ø D <sub>J</sub> [h6, f7, h8] max. min.	HOUSING Ø D <sub>H</sub> [H6, H7] max. min.		BUSH Ø D <sub>i,a</sub> ASSEMBLY IN H6/H7 HOUSING max. min.	CLEARANCE C <sub>D</sub> max. min.			
	D <sub>i</sub>	D <sub>o</sub>										
0203DU	2	3,5	0,750 0,730	3,25	2,000	3,508	2,048	0,054 0,000				
0205DU				2,75					1,994	3,500	2,000	
0303DU	5,25	3,000		4,508								3,048
0305DU	4,75								2,994	4,500	3,000	
0306DU	6,25				4,000	5,508	4,048					
0403DU	5,75	3,992		5,500					4,000			
0404DU	3,25									4,000	5,508	4,048
0406DU	2,75	3,992		5,500					4,000			
0410DU	4,25											
0505DU	3,75	5,978		8,000					5,990			
0508DU	6,25		6,987		9,015	7,055						
0510DU	5,75	6,972		9,000			6,990					
0604DU	8,25							6,972	9,000	6,990		
0606DU	7,75	6,972		9,000			6,990					
0608DU	10,25		6,972		9,000	6,990						
0610DU	9,75	6,972		9,000			6,990					
0705DU	5,25		6,972		9,000	6,990						
0710DU	4,75	6,972		9,000			6,990					
	10,25		6,972		9,000	6,990						
	9,75	6,972		9,000			6,990					

All dimensions in mm

PART NO.	NOMINAL DIAMETER		WALL THICKNESS S <sub>3</sub> max. min.	WIDTH B max. min.	SHAFT Ø D <sub>J</sub> [h6, f7, h8] max. min.	HOUSING Ø D <sub>H</sub> [H6, H7] max. min.	BUSH Ø D <sub>i,a</sub> ASSEMBLY IN H6/H7 HOUSING max. min.	CLEARANCE C <sub>D</sub> max. min.
	D <sub>i</sub>	D <sub>o</sub>						
0806DU	8	10	1,005 0,980	6,25	7,987 7,972	10,015 10,000	8,055 7,990	0,083 0,003
0808DU				5,75				
0810DU				8,25 7,75				
0812DU				10,25 9,75				
1006DU	10	12		6,25	9,987 9,972	12,018 12,000	10,058 9,990	0,086 0,003
1008DU				5,75				
1010DU				8,25 7,75				
1012DU				10,25 9,75				
1015DU				12,25 11,75				
1020DU				15,25 14,75 20,25 19,75				
1208DU	12	14		8,25	11,984 11,966	14,018 14,000	12,058 11,990	0,092 0,006
1210DU				7,75				
1212DU				10,25 9,75				
1215DU				12,25 11,75				
1220DU				15,25 14,75				
1225DU				20,25 19,75 25,25 24,75				
1310DU	13	15	10,25	12,984 12,966	15,018 15,000	13,058 12,990	0,092 0,006	
1320DU			9,75					
1405DU	14	16	5,25	13,984 13,966	16,018 16,000	14,058 13,990	0,092 0,006	
1410DU			4,75					
1412DU			10,25 9,75					
1415DU			12,25 11,75					
1420DU			15,25 14,75					
1425DU			20,25 19,75 25,25 24,75					
1510DU	15	17	10,25	14,984 14,966	17,018 17,000	15,058 14,990	0,095 0,006	
1512DU			9,75					
1515DU			12,25 11,75					
1520DU			15,25 14,75					
1525DU			20,25 19,75 25,25 24,75					
1610DU	16	18	10,25	15,984 15,966	18,018 18,000	16,058 15,990	0,095 0,006	
1612DU			9,75					
1615DU			12,25 11,75					
1620DU			15,25 14,75					
1625DU			20,25 19,75 25,25 24,75					
1720DU	17	19	20,25	16,984 16,966	19,021 19,000	17,061 16,990	0,095 0,006	

All dimensions in mm

# 7 Standard Products

PART NO.	NOMINAL DIAMETER		WALL THICKNESS S <sub>3</sub> max. min.	WIDTH B max. min.	SHAFT Ø D <sub>J</sub> [h6, f7, h8] max. min.	HOUSING Ø D <sub>H</sub> [H6, H7] max. min.	BUSH Ø D <sub>i,a</sub> ASSEMBLY IN H6/H7 HOUSING max. min.	CLEARANCE C <sub>D</sub> max. min.
	D <sub>i</sub>	D <sub>o</sub>						
1810DU	18	20	1,005 0,980	10,25 9,75	17,984 17,966	20,021 20,000	18,061 17,990	0,095 0,006
1815DU				15,25 14,75				
1820DU				20,25 19,75				
1825DU				25,25 24,75				
2010DU	20	23	1,505 1,475	10,25 9,75	19,980 19,959	23,021 23,000	20,071 19,990	0,112 0,010
2015DU				15,25 14,75				
2020DU				20,25 19,75				
2025DU				25,25 24,75				
2030DU	22	25	1,505 1,475	30,25 29,75	21,980 21,959	25,021 25,000	22,071 21,990	0,112 0,010
2215DU				15,25 14,75				
2220DU				20,25 19,75				
2225DU				25,25 24,75				
2230DU	24	27	1,505 1,475	30,25 29,75	23,980 23,959	27,021 27,000	24,071 23,990	0,112 0,010
2415DU				15,25 14,75				
2420DU				20,25 19,75				
2425DU				25,25 24,75				
2430DU	25	28	1,505 1,475	30,25 29,75	24,980 24,959	28,021 28,000	25,071 24,990	0,112 0,010
2515DU				15,25 14,75				
2520DU				20,25 19,75				
2525DU				25,25 24,75				
2530DU	28	32	2,005 1,970	30,25 29,75	27,980 27,959	32,025 32,000	28,085 27,990	0,126 0,010
2550DU				50,25 49,75				
2815DU				15,25 14,75				
2820DU				20,25 19,75				
2825DU	30	34	2,005 1,970	25,25 24,75	29,980 29,959	34,025 34,000	30,085 29,990	0,126 0,010
2830DU				30,25 29,75				
3010DU				10,25 9,75				
3015DU				15,25 14,75				
3020DU	32	36	2,005 1,970	20,25 19,75	31,975 31,950	36,025 36,000	32,085 31,990	0,135 0,015
3025DU				25,25 24,75				
3030DU				30,25 29,75				
3040DU				40,25 39,75				
3220DU	32	36	2,005 1,970	20,25 19,75	31,975 31,950	36,025 36,000	32,085 31,990	0,135 0,015
3230DU				30,25 29,75				
3240DU				40,25 39,75				

All dimensions in mm

PART NO.	NOMINAL DIAMETER		WALL THICKNESS S <sub>3</sub> max. min.	WIDTH B max. min.	SHAFT Ø D <sub>J</sub> [h6, f7, h8] max. min.	HOUSING Ø D <sub>H</sub> [H6, H7] max. min.	BUSH Ø D <sub>i,a</sub> ASSEMBLY IN H6/H7 HOUSING max. min.	CLEARANCE C <sub>D</sub> max. min.
	D <sub>i</sub>	D <sub>o</sub>						
3520DU	35	39	2,005 1,970	20,25	34,975 34,950	39,025 39,000	35,085 34,990	0,135 0,015
3530DU				19,75				
3535DU				30,25				
3540DU				29,75				
3550DU				35,25				
3720DU	37	41		34,75	36,975 36,950	41,025 41,000	37,085 36,990	
4020DU	40	44		20,25	39,975 39,950	44,025 44,000	40,085 39,990	
4030DU				19,75				
4040DU				30,25				
4050DU				29,75				
4520DU			40,25					
4530DU	39,75	45	50	40,25	44,975 44,950	50,025 50,000	45,105 44,990	
4540DU	45,25							
4545DU	44,75							
4550DU	50,25							
5020DU	49,75							
5030DU	20,25	50	55	19,75	49,975 49,950	55,030 55,000	50,110 49,990	
5040DU	30,25							
5050DU	29,75							
5060DU	40,25							
5520DU	39,75							
5525DU	50,25	55	60	49,75	54,970 54,940	60,030 60,000	55,110 54,990	
5530DU	60,25							
5540DU	59,75							
5550DU	55,25							
5555DU	54,75							
5560DU	60,25	60	65	59,75	59,970 59,940	65,030 65,000	60,110 59,990	
6020DU	20,25							
6030DU	19,75							
6040DU	30,25							
6050DU	29,75							
6060DU	40,25	2,505 2,460	0,170 0,020	39,75	59,970 59,940	65,030 65,000	60,110 59,990	
6070DU	50,25							
	49,75							
	60,25	60		65	59,75	59,970 59,940	65,030 65,000	60,110 59,990
	70,25							
	69,75							

All dimensions in mm

# 7 Standard Products

PART NO.	NOMINAL DIAMETER		WALL THICKNESS S <sub>3</sub> max. min.	WIDTH B max. min.	SHAFT Ø D <sub>f</sub> [h6, f7, h8]	HOUSING Ø D <sub>H</sub> [H6, H7]	BUSH Ø D <sub>i,a</sub> ASSEMBLY IN H6/H7 HOUSING max. min.	CLEARANCE C <sub>D</sub> max. min.	
	D <sub>i</sub>	D <sub>o</sub>							
6530DU	65	70	2,505 2,460	30,25	f7	64,970 64,940	70,030 70,000	0,170 0,020	
6550DU				29,75					
6570DU				50,25					
7040DU	49,75	69,970 69,940		75,030 75,000					
7050DU	70,25								
7070DU	69,75								
7560DU	75	80		40,25		74,970 74,940	80,030 80,000		75,110 74,990
7580DU				39,75					
8040DU	80	85		50,25		80,000 79,946	85,035 85,000		80,155 80,020
8060DU				49,75					
8080DU			70,25						
80100DU			69,75						
8530DU	85	90	60,25	85,000 84,946	90,035 90,000	85,155 85,020			
8560DU			59,75						
85100DU			80,25						
9060DU			79,75						
90100DU	90	95	100,50	90,000 89,946	95,035 95,000	90,155 90,020			
9560DU			99,50						
95100DU			100,50						
10050DU			99,50						
10060DU	95	100	60,50	95,000 94,946	100,035 100,000	95,155 95,020			
100115DU			59,50						
10560DU			100,50						
105115DU			99,50						
11060DU	100	105	60,50	100,000 99,946	105,035 105,000	100,155 100,020			
110115DU			49,50						
11560DU			60,50						
115115DU			59,50						
11550DU	105	110	115,50	105,000 104,946	110,035 110,000	105,155 105,020			
11570DU			114,50						
12050DU			60,50						
12060DU			59,50						
120100DU	110	115	115,50	110,000 109,946	115,035 115,000	110,155 110,020			
125100DU			114,50						
13060DU			50,50						
130100DU			49,50						
12050DU	115	120	70,50	115,000 114,946	120,035 120,000	115,155 115,020			
12060DU			69,50						
125100DU			50,50						
13060DU			49,50						
12050DU	120	125	50,50	120,000 119,946	125,040 125,000	120,210 120,070			
12060DU			49,50						
125100DU			60,50						
13060DU			59,50						
130100DU	125	130	100,50	125,000 124,937	130,040 130,000	125,210 125,070			
13060DU			99,50						
130100DU			60,50						
130100DU			59,50						
130100DU	130	135	100,50	130,000 129,937	135,040 135,000	130,210 130,070			
130100DU			99,50						

All dimensions in mm

PART NO.	NOMINAL DIAMETER		WALL THICKNESS S <sub>3</sub> max. min.	WIDTH B max. min.	SHAFT Ø D <sub>f</sub> [h6, f7, h8] max. min.	HOUSING Ø D <sub>H</sub> [H6, H7] max. min.	BUSH Ø D <sub>i,a</sub> ASSEMBLY IN H6/H7 HOUSING max. min.	CLEARANCE C <sub>D</sub> max. min.			
	D <sub>i</sub>	D <sub>o</sub>									
13560DU	135	140	2,465 2,415	60,50	135,000	140,040	135,210	0,273 0,070			
13580DU				59,50					134,937	140,000	135,070
14060DU	140	145		80,50	140,000	145,040	140,210				
140100DU				79,50					139,937	145,000	140,070
15060DU	150	155		60,50	150,000	155,040	150,210				
15080DU				59,50					149,937	155,000	150,070
150100DU				80,50					160,000	165,040	160,210
16080DU	79,50	165,000		160,070							
160100DU	160	165		100,50	160,000	185,046	180,216				
180100DU				99,50					159,937	185,000	180,070
200100DU	180	185		100,50	180,000	185,046	180,216		0,279 0,070		
210100DU	200	205			179,937	185,000	180,070				
220100DU	200	205			200,000	205,046	200,216		0,288 0,070		
250100DU	210	215			199,928	205,000	200,070				
300100DU	210	215			210,000	215,046	210,216				
220100DU	220	225			209,928	215,000	210,070		0,294 0,070		
250100DU	220	225	220,000		225,046	220,216					
300100DU	250	255	219,928		225,000	220,070	0,303 0,070				
300100DU	250	255	250,000	255,052	250,222						
300100DU	300	305	249,928	255,000	250,070	0,303 0,070					
300100DU	300	305	300,000	305,052	300,222						
300100DU	300	305	299,919	299,919	305,000	300,070	0,070				

All dimensions in mm

# 7 Standard Products

## 7.2 DU® FLANGED BUSHES

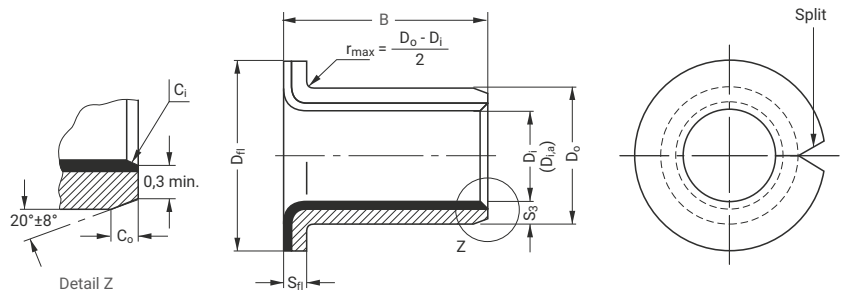

Dimensions and Tolerances according to ISO 3547 and GGB-Specifications

### Outside C<sub>0</sub> and Inside C<sub>i</sub> Chamfers

WALL THICKNESS S <sub>3</sub>	C <sub>0</sub> (a)		C <sub>i</sub> (b)
	MACHINED	ROLLED	
0,75	0,5 ± 0,3	0,5 ± 0,3	-0,1 to -0,4
1	0,6 ± 0,4	0,6 ± 0,4	-0,1 to -0,5
1,5	0,6 ± 0,4	0,6 ± 0,4	-0,1 to -0,7

WALL THICKNESS S <sub>3</sub>	C <sub>0</sub> (a)		C <sub>i</sub> (b)
	MACHINED	ROLLED	
2	1,2 ± 0,4	1,0 ± 0,4	-0,1 to -0,7
2,5	1,8 ± 0,6	1,2 ± 0,4	-0,2 to -1,0

(a) = chamfer C<sub>0</sub> machined or rolled at the opinion of the manufacturer

(b) = C<sub>i</sub> can be a radius or a chamfer in accordance with ISO 13715

PART NO.	NOMINAL DIAMETER		WALL THICKNESS S <sub>3</sub>	FLANGE THICKN. S <sub>fl</sub>	FLANGE Ø D <sub>fl</sub>	WIDTH B	SHAFT Ø D <sub>J</sub> [h6, f7, h8]		HOUSING Ø D <sub>H</sub> [H6, H7]		BUSH Ø D <sub>i,a</sub> ASSEMBLY IN H6/H7 HOUSING	CLEARANCE C <sub>D</sub>
	D <sub>i</sub>	D <sub>0</sub>					max. min.	max. min.	max. min.	max. min.		
BB0304DU	3	4,5	0,750 0,730	0,80 0,70	7,50	4,25	h6	3,000	H6	4,508	3,048	0,054
BB0404DU	4	5,5			6,50	3,75		2,994		4,500	3,000	0,000
BB0505DU	5	7	1,005 0,980	1,05 0,80	9,50	4,25	f7	4,000	H7	5,508	4,048	0,056
BB0604DU	6	8			8,50	3,75		3,992		4,500	4,000	0,000
BB0608DU	6	8	1,005 0,980	1,05 0,80	10,50	5,25	f7	4,990	H7	7,015	5,055	0,077
BB0806DU	8	10			9,50	4,75		4,978		7,000	4,990	0,000
BB0808DU	8	10	1,005 0,980	1,05 0,80	12,50	3,75	f7	5,990	H7	8,015	6,055	0,077
BB0810DU	10	12			11,50	3,75		5,978		8,000	5,990	0,000
BB1007DU	10	12	1,005 0,980	1,05 0,80	15,50	7,75	f7	7,987	H7	10,015	8,055	0,083
BB1009DU	12	14			14,50	7,25		7,972		10,000	7,990	0,003
BB1012DU	10	12	1,005 0,980	1,05 0,80	9,75	5,25	f7	9,987	H7	12,018	10,058	0,086
BB1017DU	14	16			9,25	5,25		9,972		12,000	9,990	0,003
BB1207DU	12	14	1,005 0,980	1,05 0,80	17,25	7,25	f7	11,984	H7	14,018	12,058	0,092 0,006
BB1209DU	14	16			16,75	6,75		11,966		14,000	11,990	
BB1212DU	12	14	1,005 0,980	1,05 0,80	20,50	8,75	f7	13,984	H7	16,018	14,058	0,092 0,006
BB1217DU	14	16			19,50	8,75		13,966		16,000	13,990	
BB1412DU	14	16	1,005 0,980	1,05 0,80	12,25	7,25	f7	13,984	H7	16,018	14,058	0,092 0,006
BB1417DU	16	18			21,50	6,75		13,966		16,000	13,990	

All dimensions in mm



PART NO.	NOMINAL DIAMETER		WALL THICK- NESS $S_3$	FLANGE THICKN. $S_f$	FLANGE Ø $D_f$	WIDTH B	SHAFT Ø $D_j$ [h6, f7, h8]		HOUSING Ø $D_H$ [H6, H7]		BUSH Ø $D_{i,a}$ ASSEMBLY IN H6/H7 HOUSING	CLEARANCE $C_D$				
	$D_i$	$D_o$					max. min.	max. min.	max. min.	max. min.			max. min.	max. min.		
BB1509DU	15	17	1,005 0,980	1,05 0,80	23,50 22,50	9,25	14,984 14,966	17,018 17,000	15,058 14,990	0,092 0,006						
BB1512DU						8,75										
BB1517DU						12,25 11,75										
BB1612DU	16	18			24,50 23,50	17,25					15,984 15,966	18,018 18,000	16,058 15,990			
BB1617DU						16,75										
BB1812DU	18	20			1,505 1,475	1,60 1,30					26,50 25,50	12,25	17,984 17,966	20,021 20,000	18,061 17,990	0,095 0,006
BB1817DU			11,75													
BB1822DU			17,25 16,75													
BB2012DU	20	23	1,505 1,475	1,60 1,30			30,50 29,50	11,75	19,980 19,959	23,021 23,000	20,071 19,990	0,112 0,010				
BB2017DU								11,25								
BB2022DU								16,75 16,25								
BB2512DU	25	28			1,505 1,475	1,60 1,30	35,50 34,50	21,75					24,980 24,959	28,021 28,000	25,071 24,990	0,126 0,010
BB2517DU								21,25								
BB2522DU								11,75 11,25								
BB3016DU	30	34	2,005 1,970	2,10 1,80			42,50 41,50	16,25	29,980 29,959	34,025 34,000	30,085 29,990	0,135 0,015				
BB3026DU								15,75								
BB3516DU								26,25 25,75								
BB3526DU	35	39			2,005 1,970	2,10 1,80	47,50 46,50	16,25					34,975 34,950	39,025 39,000	35,085 34,990	0,135 0,015
BB4016DU								15,75								
BB4026DU	26,25 25,75															
BB4516DU	45	50	2,505 2,460	2,60 2,30			58,50 57,50	16,25	44,975 44,950	50,025 50,000	45,105 44,990	0,155 0,015				
BB4526DU								15,75								
							2,505 2,460	2,60 2,30								

All dimensions in mm

# 7 Standard Products

## 7.3 DU® FLANGED WASHERS

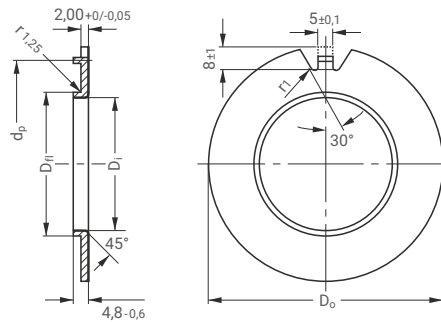

Dimensions and Tolerances according to ISO 3547 and GGB-Specifications

PART NO.	INSIDE DIAMETER $D_i$		OUTSIDE DIAMETER $D_o$		FLANGE Ø $D_f$		LOCATION Ø $d_p$	
	max.	min.	max.	min.	max.	min.	max.	min.
BS40DU	40,7		75,0		44,00		65,0	
	40,2		74,5		43,90		64,5	
BS50DU	51,5		85,0		55,00		75,0	
	51,0		84,5		54,88		74,5	
BS60DU	61,5		95,0		65,00		85,0	
	61,0		94,5		64,88		84,5	
BS70DU	71,5		110,0		75,00		100,0	
	71,0		109,5		74,88		99,5	
BS80DU	81,5		120,0		85,00		110,0	
	81,0		119,5		84,86		109,5	
BS90DU	91,5		130,0		95,00		120,0	
	91,0		129,5		94,86		119,5	
BS100DU	101,5		140,0		105,00		130,0	
	101,0		139,5		104,86		129,5	

All dimensions in mm

## 7.4 DU® THRUST WASHERS

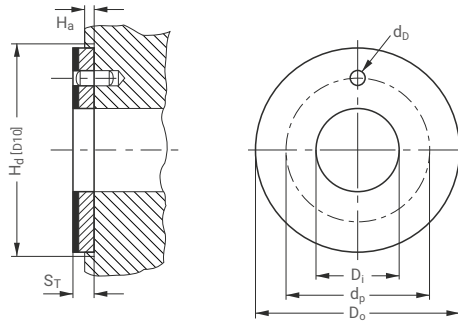

Dimensions and Tolerances according to ISO 3547 and GGB-Specifications

PART NO.	INSIDE DIAMETER $D_i$		OUTSIDE DIAMETER $D_o$		THICKNESS $S_T$ max. min.	DOWEL HOLE		RECESS DEPTH $H_a$ max. min.
	max.	min.	max.	min.		$\emptyset d_b$ max. min.	PCD $\emptyset d_p$ max. min.	
WC08DU	10,25	10,00	20,00	19,75	1,50 1,45	No Hole	No Hole	1,20 0,95
WC10DU	12,25	12,00	24,00	23,75		1,875 1,625	18,12 17,88	
WC12DU	14,25	14,00	26,00	25,75		2,375 2,125	20,12 19,88	
WC14DU	16,25	16,00	30,00	29,75			22,12 21,88	
WC16DU	18,25	18,00	32,00	31,75		3,375 3,125	25,12 24,88	
WC18DU	20,25	20,00	36,00	35,75			28,12 27,88	
WC20DU	22,25	22,00	38,00	37,75		4,375 4,125	30,12 29,88	
WC22DU	24,25	24,00	42,00	41,75			33,12 32,88	
WC24DU	26,25	26,00	44,00	43,75		1,70 1,45	35,12 34,88	
WC25DU	28,25	28,00	48,00	47,75			38,12 37,88	
WC30DU	32,25	32,00	54,00	53,75		1,70 1,45	43,12 42,88	
WC35DU	38,25	38,00	62,00	61,75			50,12 49,88	
WC40DU	42,25	42,00	66,00	65,75		1,70 1,45	54,12 53,88	
WC45DU	48,25	48,00	74,00	73,75			61,12 60,88	
WC50DU	52,25	52,00	78,00	77,75	1,70 1,45	65,12 64,88		
WC60DU	62,25	62,00	90,00	89,75		76,12 75,88		

All dimensions in mm

# 7 Standard Products

## 7.5 DU-B CYLINDRICAL BUSHES

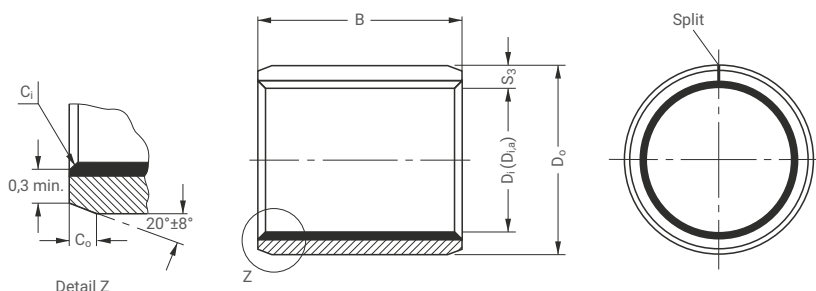

Dimensions and Tolerances according to ISO 3547 and GGB-Specifications

### Outside $C_o$ and Inside $C_i$ Chamfers

WALL THICKNESS $S_3$	$C_o$ (a)		$C_i$ (b)
	MACHINED	ROLLED	
0,75	$0,5 \pm 0,3$	$0,5 \pm 0,3$	-0,1 to -0,4
1	$0,6 \pm 0,4$	$0,6 \pm 0,4$	-0,1 to -0,5
1,5	$0,6 \pm 0,4$	$0,6 \pm 0,4$	-0,1 to -0,7

WALL THICKNESS $S_3$	$C_o$ (a)		$C_i$ (b)
	MACHINED	ROLLED	
2	$1,2 \pm 0,4$	$1,0 \pm 0,4$	-0,1 to -0,7
2,5	$1,8 \pm 0,6$	$1,2 \pm 0,4$	-0,2 to -1,0

(a) = chamfer  $C_o$  machined or rolled at the opinion of the manufacturer

(b) =  $C_i$  can be a radius or a chamfer in accordance with ISO 13715

PART NO.	NOMINAL DIAMETER		WALL THICKNESS $S_3$ max. min.	WIDTH B max. min.	SHAFT Ø $D_j$ [h6, f7, h8] max. min.	HOUSING Ø $D_H$ [H6, H7] max. min.	BUSH Ø $D_{i,a}$ ASSEMBLY IN H6/H7 HOUSING max. min.	CLEARANCE $C_D$ max. min.									
	$D_i$	$D_o$															
0203DUB	2	3,5	0,750 0,730	3,25	h6	H6	2,000 1,994	3,508 3,500	2,048 2,000								
0205DUB				5,25						4,75	4,508 4,500	3,048 3,000					
0306DUB	3	4,5		6,25						5,75	4,000 3,992	5,508 5,500	4,048 4,000				
0404DUB				4						5,5	4,25	3,75	7,015 7,000	5,055 4,990			
0406DUB	6,25	5,75									5,990 5,978	8,015 8,000	6,055 5,990				
0505DUB	5	7		5,25						f7	H7	7,987 7,972	10,015 10,000	8,055 7,990			
0510DUB				10,25	9,75	10,015 10,000	8,055 7,990										
0606DUB	6	8		6,25	5,75	9,987 9,972	12,018 12,000	10,058 9,990									
0608DUB				8,25	7,75	11,984 11,966	14,018 14,000	12,058 11,990									
0610DUB	10	12		10,25	1,005 0,980	H7	14,018 14,000	12,058 11,990	0,086 0,003								
1010DUB				9,75											9,972	12,018 12,000	10,058 9,990
1015DUB	15,25	14,75		11,984 11,966											14,018 14,000	12,058 11,990	
1208DUB	12	14	8,25	7,75											14,018 14,000	12,058 11,990	0,092 0,006
1210DUB			10,25	9,75											14,018 14,000	12,058 11,990	
1212DUB	12,25	11,75	14,018 14,000	12,058 11,990											0,092 0,006		
1215DUB	15,25	14,75	14,018 14,000	12,058 11,990											0,092 0,006		

All dimensions in mm

PART NO.	NOMINAL DIAMETER		WALL THICKNESS S <sub>3</sub> max. min.	WIDTH B max. min.	SHAFT Ø D <sub>J</sub> [h6, f7, h8] max. min.	HOUSING Ø D <sub>H</sub> [H6, H7] max. min.	BUSH Ø D <sub>i,a</sub> ASSEMBLY IN H6/H7 HOUSING max. min.	CLEARANCE C <sub>D</sub> max. min.
	D <sub>i</sub>	D <sub>o</sub>						
1410DUB	14	16	1,005 0,980	10,25	13,984 13,966	16,018 16,000	14,058 13,990	0,092 0,006
1415DUB				9,75				
1420DUB				15,25				
1515DUB	14,75							
1525DUB	20,25							
1615DUB	19,75							
1625DUB	15,25	14,984 14,966		17,018 17,000	15,058 14,990			
1820DUB	14,75							
1825DUB	25,25							
2015DUB	24,75	15,984 15,966				18,018 18,000	16,058 15,990	
2020DUB	20,25							
2025DUB	19,75							
2030DUB	25,25	17,984 17,966	20,021 20,000	18,061 17,990				
2215DUB	24,75							
2220DUB	20,25							
2225DUB	19,75	19,980 19,959			23,021 23,000	20,071 19,990		
2515DUB	25,25							
2525DUB	24,75							
2830DUB	30,25	21,980 21,959	25,021 25,000	22,071 21,990				
3020DUB	29,75							
3030DUB	15,25							
3040DUB	14,75	24,980 24,959			28,021 28,000	25,071 24,990		
3520DUB	25,25							
3530DUB	24,75							
4030DUB	30,25	27,980 27,959	32,025 32,000	28,085 27,990				
4050DUB	29,75							
4530DUB	20,25							
4550DUB	19,75	29,980 29,959			34,025 34,000	30,085 29,990		
5040DUB	40,25							
5060DUB	39,75							
5540DUB	20,25	34,975 34,950	39,025 39,000	35,085 34,990				
6050DUB	19,75							
6060DUB	30,25							
6070DUB	29,75	39,975 39,950			44,025 44,000	40,085 39,990		
6570DUB	50,25							
	49,75							
6050DUB	30,25	44,975 44,950	50,025 50,000	45,105 44,990				
6060DUB	29,75							
6070DUB	50,25							
6570DUB	49,75	49,975 49,950			55,030 55,000	50,110 49,990		
	60,25							
	59,75							
6050DUB	40,25	54,970 54,940	60,030 60,000	55,110 54,990				
6060DUB	39,75							
6070DUB	40,25							
6570DUB	39,75	59,970 59,940			65,030 65,000	60,110 59,990		
	50,25							
	49,75							
6050DUB	60,25	64,970 64,940	70,030 70,000	65,110 64,990				
6060DUB	59,75							
6070DUB	70,25							
6570DUB	69,75							

All dimensions in mm

# 7 Standard Products

PART NO.	NOMINAL DIAMETER		WALL THICKNESS S <sub>3</sub> max. min.	WIDTH B max. min.	SHAFT Ø D <sub>f</sub> [h6, f7, h8] max. min.	HOUSING Ø D <sub>H</sub> [H6, H7] max. min.	BUSH Ø D <sub>i,a</sub> ASSEMBLY IN H6/H7 HOUSING max. min.	CLEARANCE C <sub>D</sub> max. min.	
	D <sub>i</sub>	D <sub>o</sub>							
7050DUB	70	75	2,505 2,460	50,25 49,75	f7	69,970 69,940	75,030 75,000	70,110 69,990	0,170 0,020
7070DUB				70,25 69,75					
7580DUB	75	80		80,25 79,75					
8060DUB	80	85	2,490 2,440	60,50 59,50	h8	80,000 79,946	85,035 85,000	80,155 80,020	0,201 0,020
80100DUB				100,50 99,50					
85100DUB	85	90		100,50 99,50	85,000 84,946	90,035 90,000	85,155 85,020		
9060DUB	90	95		60,50 59,50	H7	90,000 89,946	95,035 95,000	90,155 90,020	0,209 0,020
90100DUB				100,50 99,50					
95100DUB	95	100		100,50 99,50	95,000 94,946	100,035 100,000	95,155 95,020		
10060DUB	100	105		60,50 59,50	H7	100,000 99,946	105,035 105,000	100,155 100,020	0,209 0,020
100115DUB				115,50 114,50					
105115DUB	105	110		115,50 114,50	105,000 104,946	110,035 110,000	105,155 105,020		
110115DUB	110	115		115,50 114,50	110,000 109,946	115,035 115,000	115,155 115,020		

All dimensions in mm

## 7.6 DU-B FLANGED BUSHES

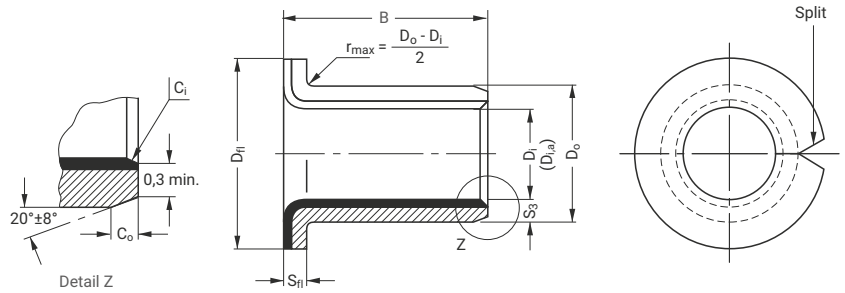

Dimensions and Tolerances according to ISO 3547 and GGB-Specifications

### Outside $C_0$ and Inside $C_i$ Chamfers

WALL THICKNESS $S_3$	$C_0$ (a)		$C_i$ (b)
	MACHINED	ROLLED	
0,75	$0,5 \pm 0,3$	$0,5 \pm 0,3$	-0,1 to -0,4
1	$0,6 \pm 0,4$	$0,6 \pm 0,4$	-0,1 to -0,5
1,5	$0,6 \pm 0,4$	$0,6 \pm 0,4$	-0,1 to -0,7

WALL THICKNESS $S_3$	$C_0$ (a)		$C_i$ (b)
	MACHINED	ROLLED	
2	$1,2 \pm 0,4$	$1,0 \pm 0,4$	-0,1 to -0,7
2,5	$1,8 \pm 0,6$	$1,2 \pm 0,4$	-0,2 to -1,0

(a) = chamfer  $C_0$  machined or rolled at the opinion of the manufacturer

(b) =  $C_i$  can be a radius or a chamfer in accordance with ISO 13715

PART NO.	NOMINAL DIAMETER		WALL THICKNESS $S_3$	FLANGE THICKN. $S_{fl}$	FLANGE Ø $D_{fl}$	WIDTH B	SHAFT Ø $D_j$ [h6, f7, h8]	HOUSING Ø $D_H$ [H6, H7]	BUSH Ø $D_{i,a}$ ASSEMBLY IN H6/H7 HOUSING	CLEARANCE $C_D$						
	$D_i$	$D_0$									max. min.	max. min.	max. min.	max. min.	max. min.	max. min.
BB0304DUB	3	4,5	0,750 0,730	0,80 0,70	7,50	4,25	h6	H6	3,000 2,994	4,508 4,500	3,048 3,000	0,054 0,000				
BB0404DUB	4	5,5			9,50 8,50	4,25 3,75							4,000 3,992	5,508 4,500	4,048 4,000	
BB0505DUB	5	7	1,005 0,980	1,05 0,80	10,50 9,50	5,25 4,75	f7	H7	4,990 4,978	7,015 7,000	5,055 4,990	0,077 0,000				
BB0604DUB	6	8			12,50	4,25 3,75							5,990 5,978	8,015 8,000	6,055 5,990	0,077 0,000
BB0608DUB					11,50	8,25 7,75										
BB0806DUB	8	10			15,50	5,75 5,25							7,987 7,972	10,015 10,000	8,055 7,990	0,083 0,003
BB0810DUB					14,50	9,75 9,25										
BB1007DUB	10	12			18,50	7,25 6,75							9,987 9,972	12,018 12,000	10,058 9,990	0,086 0,003
BB1012DUB					17,50	12,25 11,75										
BB1207DUB	12	14			20,50	7,25 6,75							11,984 11,966	14,018 14,000	12,058 11,990	0,092 0,006
BB1209DUB					19,50	9,25 8,75										
BB1212DUB					12,25 11,75											
BB1417DUB			22,50 21,50	17,25 16,75												
BB1512DUB	15	17	23,50	12,25 11,75	14,984 14,966	17,018 17,000	15,058 14,990	0,092 0,006								
BB1517DUB			22,50	17,25 16,75												
BB1612DUB	16	18	24,50	12,25 11,75	15,984 15,966	18,018 18,000	16,058 15,990	0,092 0,006								
BB1617DUB			23,50	17,25 16,75												

All dimensions in mm

# 7 Standard Products

PART NO.	NOMINAL DIAMETER		WALL THICK- NESS $S_3$ max. min.	FLANGE THICKN. $S_{fl}$ max. min.	FLANGE Ø $D_{fl}$ max. min.	WIDTH B max. min.	SHAFT Ø $D_j$ [h6, f7, h8] max. min.	HOUSING Ø $D_H$ [H6, H7] max. min.	BUSH Ø $D_{i,a}$ ASSEMBLY IN H6/H7 HOUSING max. min.	CLEARANCE $C_D$ max. min.
	$D_i$	$D_o$								
BB1812DUB	18	20	1,005 0,980	1,05 0,80	26,50 25,50	12,25	17,984 17,966	20,021 20,000	18,061 17,990	0,095 0,006
BB1822DUB						11,75				
BB2012DUB	20	23	1,505 1,475	1,60 1,30	30,50 29,50	11,75	19,980 19,959	23,021 23,000	20,071 19,990	0,112 0,010
BB2017DUB						11,25				
BB2512DUB	25	28	1,505 1,475	1,60 1,30	35,50 34,50	11,75	24,980 24,959	28,021 28,000	25,071 24,990	0,112 0,010
BB2522DUB						11,25				
BB3016DUB	30	34	2,005 1,970	2,10 1,80	42,50 41,50	16,25	29,980 29,959	34,025 34,000	30,085 29,990	0,126 0,010
BB3026DUB						15,75				
BB3526DUB	35	39	2,005 1,970	2,10 1,80	47,50	26,25 25,75	34,975 34,950	39,025 39,000	35,085 34,990	0,135 0,015
BB3526DUB	46,50									
BB4026DUB	40	44	2,005 1,970	2,10 1,80	53,50	26,25 25,75	39,975 39,950	44,025 44,000	40,085 39,990	0,135 0,015
BB4026DUB	52,50									
BB4526DUB	45	50	2,505 2,460	2,60 2,30	58,50 57,50	26,25 25,75	44,975 44,950	50,025 50,000	45,105 44,990	0,155 0,015

All dimensions in mm



## 7.7 DU® CYLINDRICAL BUSHES - INCH SIZES

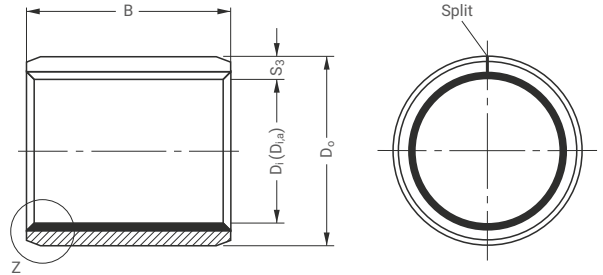
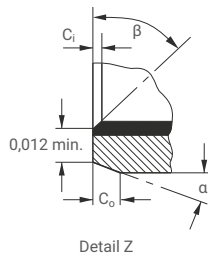

### Outside C<sub>o</sub> and Inside C<sub>i</sub> Chamfers

D <sub>i</sub>	C <sub>o</sub>	α	C <sub>i</sub>	β
1/8" - 5/16	0,008" - 0,024	30°-4	0,004" - 0,012	30°-45°
3/8" - 11/16	0,020" - 0,040	20°-3	0,005" - 0,025	40°-55°
3/4" - 7	0,020" - 0,040	15°-25	0,005" - 0,025	40°-50°

PART NO.	NOMINAL DIAMETER			WALL THICKNESS S <sub>3</sub> max. min.	WIDTH B max. min.	SHAFT Ø D <sub>J</sub> max. min.	HOUSING Ø D <sub>H</sub> max. min.	BUSH Ø D <sub>i,a</sub> ASSEMBLY IN D <sub>H</sub> HOUSING max. min.	CLEARANCE C <sub>D</sub> max. min.		
	D <sub>i</sub>	D <sub>o</sub>	B								
02DU02	1/8	3/16	1/8	0,0315 0,0305	0,1350	0,1243	0,1878	0,1268	0,0032		
02DU03			3/16		0,1150					0,1236	0,1243
025DU025	5/32	7/32	5/32		0,16625	0,1554	0,2191	0,1581	0,0034		
025DU04			1/4		0,14265					0,1547	0,2186
03DU03	3/16	1/4	3/16		0,1975	0,1865	0,2503	0,1893	0,0035		
03DU04			1/4		0,1775					0,2497	0,1867
03DU06			3/8		0,2600					0,3650	0,3650
04DU04	1/4	5/16	1/4		0,2600	0,2490	0,3128	0,2518	0,0037 0,0002		
04DU06			3/8		0,2400					0,3122	0,2492
05DU06			3/8		0,3850					0,3650	0,3753
05DU08	5/16	3/8	1/2		0,5100	0,3115	0,3747	0,3143			
06DU06			3/8		0,4900					0,3747	0,3117
06DU08	3/8	15/32	1/2	0,3850	0,3740	0,4691	0,3769	0,0038			
06DU12			3/4	0,3650					0,4684	0,3742	
07DU08			7/16	17/32					1/2	0,5100	0,4365
07DU12	3/4	0,4900			0,5309	0,4367					
08DU06	1/2	19/32			3/8	0,7600	0,4990	0,5941	0,5019		
08DU08			1/2	0,7400	0,5934	0,4992					
08DU10			5/8	0,5100	0,5941	0,4992					
08DU14			7/8	0,4900	0,5941	0,4992					
09DU08			1/2	0,6350	0,6150	0,5941				0,4992	
09DU12	9/16	21/32	1/2	0,8850	0,5615	0,6566	0,5644	0,0039			
09DU12			3/4	0,8650					0,6559	0,5617	

All dimensions in inches

# 7 Standard Products

PART NO.	NOMINAL DIAMETER			WALL THICKNESS S <sub>3</sub> max. min.	WIDTH B max. min.	SHAFT Ø D <sub>J</sub> max. min.	HOUSING Ø D <sub>H</sub> max. min.	BUSH Ø D <sub>i,a</sub> ASSEMBLY IN D <sub>H</sub> HOUSING max. min.	CLEARANCE C <sub>D</sub> max. min.
	D <sub>i</sub>	D <sub>o</sub>	B						
10DU08	5/8	23/32	1/2	0,0471 0,0461	0,5100 0,4900	0,6240 0,6230	0,7192 0,7184	0,6270 0,6242	0,0040 0,0002
10DU10			5/8		0,6350 0,6150				
10DU12			3/4		0,7600 0,7400				
10DU14			7/8		0,8850 0,8650				
11DU14			11/16		25/32				
12DU08	3/4	7/8	1/2	0,0627 0,0615	0,5100 0,4900	0,7491 0,7479	0,8755 0,8747	0,7525 0,7493	0,0046 0,0002
12DU12			3/4		0,7600 0,7400				
12DU16			1		1,0100 0,9900				
14DU12			3/4		0,7600 0,7400				
14DU14	7/8	1	7/8	0,0627 0,0615	0,8850 0,8650	0,8741 0,8729	1,0005 0,9997	0,8775 0,8743	0,0047 0,0001
14DU16			1		1,0100 0,9900				
16DU12			3/4		0,7600 0,7400				
16DU16	1	1 1/8	1	0,0784 0,0770	1,0100 0,9900	0,9991 0,9979	1,1256 1,1246	1,0026 0,9992	0,0052 0,0002
16DU24			1 1/2		1,5100 1,4900				
18DU12			3/4		0,7600 0,7400				
18DU16	1 1/8	1 9/32	1	0,0784 0,0770	1,0100 0,9900	1,1238 1,1226	1,2818 1,2808	1,1278 1,1240	0,0052 0,0002
20DU12			3/4		0,7600 0,7400				
20DU16	1 1/4	1 13/32	1	0,0784 0,0770	1,0100 0,9900	1,2488 1,2472	1,4068 1,4058	1,2528 1,2490	0,0056 0,0002
20DU20			1 1/4		1,2600 1,2400				
20DU28			1 3/4		1,7600 1,7400				
22DU16			1		1,0100 0,9900				
22DU22	1 3/8	1 17/32	1 3/8	0,0784 0,0770	1,3850 1,3650	1,3738 1,3722	1,5318 1,5308	1,3778 1,3740	0,0056 0,0002
22DU28			1 3/4		1,7600 1,7400				
24DU16			1		1,0100 0,9900				
24DU20	1 1/2	1 21/32	1 1/4	0,0941 0,0923	1,2600 1,2400	1,4988 1,4972	1,6568 1,6558	1,5028 1,4990	0,0064 0,0002
24DU24			1 1/2		1,5100 1,4900				
24DU32			2		2,0100 1,9900				
26DU16			1		1,0100 0,9900				
26DU24	1 5/8	1 25/32	1 1/2	0,0941 0,0923	1,5100 1,4900	1,6238 1,6222	1,7818 1,7808	1,6278 1,6240	0,0056 0,0002
28DU16			1		1,0100 0,9900				
28DU24	1 3/4	1 15/16	1 1/2	0,0941 0,0923	1,5100 1,4900	1,7487 1,7471	1,9381 1,9371	1,7535 1,7489	0,0064 0,0002
28DU28			1 3/4		1,7600 1,7400				
28DU32			2		2,0100 1,9900				

All dimensions in inches

PART NO.	NOMINAL DIAMETER			WALL THICKNESS S <sub>3</sub> max. min.	WIDTH B max. min.	SHAFT Ø D <sub>J</sub> max. min.	HOUSING Ø D <sub>H</sub> max. min.	BUSH Ø D <sub>i,a</sub> ASSEMBLY IN D <sub>H</sub> HOUSING max. min.	CLEARANCE C <sub>D</sub> max. min.
	D <sub>i</sub>	D <sub>o</sub>	B						
30DU16	1 <sup>7/8</sup>	2 <sup>1/16</sup>	1	0,0941 0,0923	1,0100 0,9900	1,8737 1,8721	2,0633 2,0621	1,8787 1,8739	0,0066 0,0002
30DU30			1 <sup>7/8</sup>		1,8850 1,8650				
30DU36			2 <sup>1/4</sup>		2,2600 2,2400				
32DU16	2	2 <sup>3/16</sup>	1	0,0928 0,0902	1,0100 0,9900	1,9987 1,9969	2,1883 2,1871	2,0037 1,9989	0,0068 0,0002
32DU24			1 <sup>1/2</sup>		1,5100 1,4900				
32DU32			2		2,0100 1,9900				
32DU40			2 <sup>1/2</sup>		2,5100 2,4900				
36DU32	2 <sup>1/4</sup>	2 <sup>7/16</sup>	2	0,0928 0,0902	2,0100 1,4900	2,2507 2,2489	2,4377 2,4365	2,2573 2,2509	0,0084 0,0002
36DU36			2 <sup>1/4</sup>		2,2600 2,2400				
36DU40			2 <sup>1/2</sup>		2,5100 2,4900				
36DU48			3		3,0100 2,9900				
40DU32	2 <sup>1/2</sup>	2 <sup>11/16</sup>	2	0,0928 0,0902	2,0100 1,9900	2,5011 2,4993	2,6881 2,6869	2,5077 2,5013	0,0086 0,0002
40DU40			2 <sup>1/2</sup>		2,5100 2,4900				
40DU48			3		3,0100 2,9900				
40DU56			3 <sup>1/2</sup>		3,5100 3,4900				
44DU32	2 <sup>3/4</sup>	2 <sup>15/16</sup>	2	0,0928 0,0902	2,0100 1,9900	2,7500 2,7482	2,9370 2,9358	2,7566 2,7502	0,0090 0,0002
44DU40			2 <sup>1/2</sup>		2,5100 2,4900				
44DU48			3		3,0100 2,9900				
44DU56			3 <sup>1/2</sup>		3,5100 3,4900				
48DU32	3	3 <sup>3/16</sup>	2	0,0928 0,0902	2,5100 2,4900	3,0000 2,9982	3,1872 3,1858	3,0068 3,0002	0,0095 0,0002
48DU48			3		3,0100 2,9900				
48DU60			3 <sup>3/4</sup>		3,7600 3,7400				
56DU40	3 <sup>1/2</sup>	3 <sup>11/16</sup>	2 <sup>1/2</sup>	0,0928 0,0902	2,5100 2,4900	3,5000 3,4978	3,6872 3,6858	3,5068 3,5002	0,0097 0,0002
56DU48			3		3,0100 2,9900				
56DU60			3 <sup>3/4</sup>		3,7600 3,7400				
64DU48	4	4 <sup>3/16</sup>	3	0,0928 0,0902	3,0100 2,9900	4,0000 3,9978	4,1872 4,1858	4,0068 4,0002	0,0099 0,0002
64DU60			3 <sup>3/4</sup>		3,7600 3,7400				
64DU76			4 <sup>3/4</sup>		4,7600 4,7400				
80DU48	5	5 <sup>3/16</sup>	3	0,0928 0,0902	3,0100 2,9900	4,9986 4,9961	5,1860 5,1844	5,0056 4,9988	0,0099 0,0002
80DU60			3 <sup>3/4</sup>		3,7600 3,7400				
96DU48	6	6 <sup>3/16</sup>	3	0,0928 0,0902	3,0100 2,9900	6,0000 5,9975	6,1874 6,1858	6,0070 6,0002	0,0099 0,0002
96DU60			3 <sup>3/4</sup>		3,7600 3,7400				
112DU60	7	7 <sup>3/16</sup>	3 <sup>3/4</sup>	0,0928 0,0902	3,7600 3,7400	6,9954 6,9929	7,1830 7,1812	7,0026 6,9956	0,0097 0,0002

All dimensions in inches

# 7 Standard Products

## 7.8 DU® THRUST WASHERS - INCH SIZES

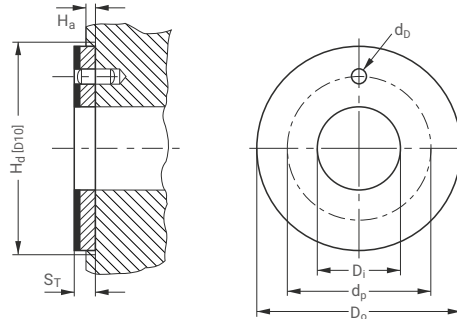

PART NO.	INSIDE DIAMETER $D_i$		OUTSIDE DIAMETER $D_o$		THICKNESS $S_T$ max. min.	DOWEL HOLE		RECESS DEPTH $H_a$ max. min.
	max.	min.	max.	min.		$\emptyset d_b$ max. min.	PCD $\emptyset d_p$ max. min.	
DU06	0,510	0,500	0,875	0,865	0,063 0,061	0,077 0,067	0,692	0,050 0,040
DU07	0,572	0,562	1,000	0,990			0,786	
DU08	0,635	0,625	1,125	1,115		0,109 0,099	0,776	
DU09	0,697	0,687	1,187	1,177			0,880	
DU10	0,760	0,750	1,250	1,240		0,942		
DU11	0,822	0,812	1,375	1,365		0,932		
DU12	0,885	0,875	1,500	1,490		1,005		
DU14	1,010	1,000	1,750	1,740		0,995		
DU16	1,135	1,125	2,000	1,990		1,099		
DU18	1,260	1,250	2,125	2,115		1,089		
DU20	1,385	1,375	2,250	2,240		1,192		
DU22	1,510	1,500	2,500	2,490		1,182		
DU24	1,635	1,625	2,625	2,615		1,380		
DU26	1,760	1,750	2,750	2,740		1,370		
DU28	2,010	2,000	3,000	2,990	1,567			
DU30	2,135	2,125	3,125	3,115	1,557			
DU32	2,260	2,250	3,250	3,240	1,692			
					0,093 0,091	0,171 0,161	1,682	0,080 0,070
				1,817				
				1,807				
				2,005				
					0,202 0,192	2,005 1,995	1,995	
				2,130				
				2,120				
				2,255				
					0,202 0,192	2,245	2,245	
				2,505				
				2,495				
				2,630				
					0,093 0,091	2,620	2,620	0,080 0,070
				2,755				
						2,745		

All dimensions in inches

## 7.9 DU® STRIP

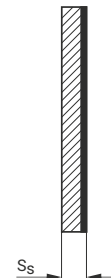
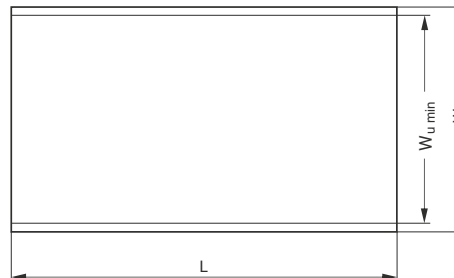
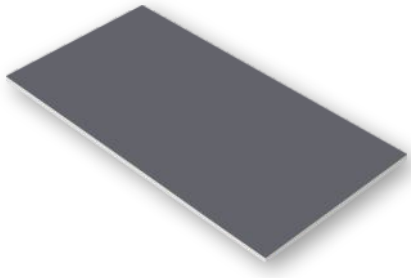

PART NO.	LENGTH L max. min.	TOTAL WIDTH W	USABLE WIDTH W <sub>U min</sub>	THICKNESS S <sub>s</sub> max. min.
S07190DU	503 500	200	190	0,74
S10190DU				0,70
S15190DU				1,01
S20190DU				0,97
S25190DU				1,52
S30190DU				1,48
				2,00
				1,96
				2,50
				2,46
				3,06
				3,02

All dimensions in mm

## 7.10 DU-B STRIP

PART NO.	LENGTH L max. min.	TOTAL WIDTH W	USABLE WIDTH W <sub>U min</sub>	THICKNESS S <sub>s</sub> max. min.
S07085DUB	503 500	95	85	0,74
S10180DUB		193	180	0,70
S15180DUB				1,01
S20180DUB				0,97
S25180DUB				1,52
				1,48
	2,00			
	1,96			
	2,50			
	2,46			

All dimensions in mm

## 7.11 DU® STRIP - INCH SIZES

DU® Strip inch sizes are available as Non-Standard products, on request.

# 8 Test Methods

## 8.1 MEASUREMENT OF WRAPPED BUSHES

It is not possible to accurately measure the external and internal diameters of a wrapped bush in the free condition. In its free state a wrapped bush will not be perfectly cylindrical and the butt joint may be open. When correctly installed in a housing the butt joint will be tightly closed and the bush will conform to the housing. For this reason the external diameter and internal diameter of a wrapped bush can only be checked with special gauges and test equipment.

The checking methods are defined in ISO 3547 Parts 1 to 7.

### Test A of ISO 3547 Part 2

Checking the external diameter in a test machine with checking blocks and adjusting mandrel.

TEST A OF ISO 3547 PART 2 ON 2015DU	
Checking block and setting mandrel $d_{ch,1}$	23,062 mm
Test force $F_{ch}$	4500 N
Limits for $\Delta z$	0 and -0,065 mm
Bush Outside diameter $D_o$	23,035 to 23,075 mm

Table 14 : Test A of ISO 3547 Part 2

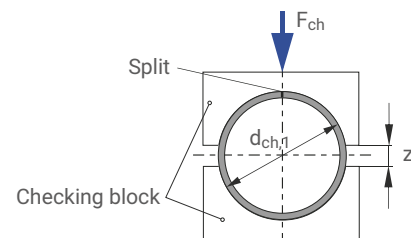

Fig.34 : Test A, data for drawing

### Test B (alternatively to Test A)

Check external diameter with GO and NO GO ring gauges.

### Test C

Checking the internal diameter of a bush pressed into a ring gauge, which nominal diameter corresponds to the dimension specified in table 6 of ISO 3547 Part 2 (Example  $D_j = 20$  mm).

### Measurement of Wall Thickness (alternatively to Test C)

The wall thickness is measured at one, two or three positions axially according to the bearing dimensions.

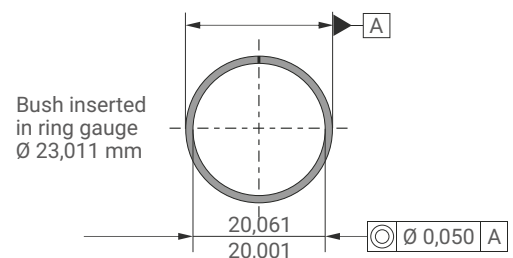

Fig.35 : Test C, data for drawing

B [mm]	X [mm]	MEASUREMENT POSITION
≤15	B/2	1
>15 ≤50	4	2
>50 ≤90	6 and B/2	3
>90	8 and B/2	3

Table 15 : Measurement position

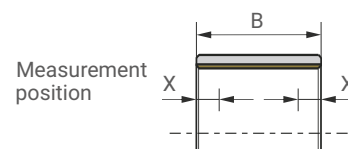

Fig.36 : Test C, measurement position

### Test D

Check external diameter by precision measuring tape.

## FORMULA SYMBOLS AND DESIGNATIONS

SYMBOL	UNIT	DESIGNATION
A	mm <sup>2</sup>	Surface area of DU® bearing
A <sub>M</sub>	mm <sup>2</sup>	Surface area of mating surface in contact with DU® bearing (slideway)
a <sub>B</sub>	-	Bearing size factor
a <sub>C</sub>	-	Application factor for bore burnishing or machining
a <sub>E</sub>	-	High load factor
a <sub>E1</sub>	-	Specific load factor (slideways)
a <sub>E2</sub>	-	Speed, temperature and material factor (slideways)
a <sub>E3</sub>	-	Relative contact area factor (slideways)
a <sub>L</sub>	-	Life correction constant
a <sub>M</sub>	-	Mating surface material factor
a <sub>T</sub>	-	Temperature application factor
B	mm	Nominal bush length
C	1/min	Dynamic load frequency
C <sub>D</sub>	mm	Installed diametrical clearance
C <sub>i</sub>	mm	ID chamfer length
C <sub>o</sub>	mm	OD chamfer length
C <sub>T</sub>	-	Total number of dynamic load cycles
D <sub>C</sub>	mm	Diameter of burnishing tool
D <sub>fl</sub>	mm	Nominal bush flange OD
D <sub>H</sub>	mm	Housing Diameter
D <sub>i</sub>	mm	Nominal bush and thrust washer ID
D <sub>i,a</sub>	mm	Bush ID when assembled in housing
D <sub>J</sub>	mm	Shaft diameter
D <sub>Nth</sub>	nvt	Max. thermal neutron dose
D <sub>o</sub>	mm	Nominal bush and thrust washer OD
D <sub>γ</sub>	Gy	Max. Gamma radiation dose
d <sub>ch,1</sub>	mm	Checking block diameter
d <sub>D</sub>	mm	Dowel hole diameter
d <sub>L</sub>	mm	Oil hole diameter
d <sub>p</sub>	mm	Pitch circle diameter for dowel hole
F	N	Bearing load
F <sub>ch</sub>	N	Test force
F <sub>i</sub>	N	Insertion force
f	-	Friction

SYMBOL	UNIT	DESIGNATION
H <sub>a</sub>	mm	Depth of housing recess (e.g. for thrust washers)
H <sub>d</sub>	mm	Diameter of housing recess (e.g. for thrust washers)
L	mm	Strip length
L <sub>H</sub>	h	Bearing service life
L <sub>S</sub>	mm	Length of stroke (slideway)
N	1/min	Rotational speed
N <sub>osz</sub>	1/min	Oscillating movement frequency
p	N/mm <sup>2</sup>	Specific load
p <sub>lim</sub>	N/mm <sup>2</sup>	Specific load limit
p <sub>sta,max</sub>	N/mm <sup>2</sup>	Maximum static load
p <sub>dyn,max</sub>	N/mm <sup>2</sup>	Maximum dynamic load
Q	-	Permissible number of cycles
R <sub>a</sub>	μm	Surface roughness (DIN 4768, ISO/DIN 4287/1)
R <sub>OB</sub>	Ω	Electrical resistance
s <sub>3</sub>	mm	Bush wall thickness
s <sub>fl</sub>	mm	Flange thickness
s <sub>S</sub>	mm	Strip thickness
s <sub>T</sub>	mm	Thrust washer thickness
T	°C	Temperature
T <sub>amb</sub>	°C	Ambient temperature
T <sub>max</sub>	°C	Maximum temperature
T <sub>min</sub>	°C	Minimum temperature
U	m/s	Sliding speed
W	mm	Strip width
W <sub>U min</sub>	mm	Minimum usable strip width
Z <sub>T</sub>	-	Total number of cycles
α <sub>1</sub>	1/10 <sup>6</sup> K	Coefficient of linear thermal expansion parallel to surface
α <sub>2</sub>	1/10 <sup>6</sup> K	Coefficient of linear thermal expansion normal to surface
σ <sub>c</sub>	N/mm <sup>2</sup>	Compressive yield strength
λ	W/mK	Thermal conductivity
φ	°	Angular displacement
η	Ns/mm <sup>2</sup>	Dynamic viscosity

# 9 Bearing Application Data Sheet



Not sure which GGB part fits your application requirements?

Please complete the form below and share it with your GGB sales person or distributor representative.

## DATA FOR BEARING DESIGN CALCULATION

Application: \_\_\_\_\_

Project/No.: \_\_\_\_\_ Quantity: \_\_\_\_\_  New Design  Existing Design

Steady load  Rotating load  Rotational movement  Oscillating movement  Linear movement

### BEARING TYPE

Cylindrical bush

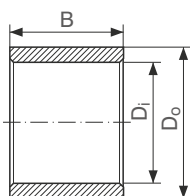

Flanged bush

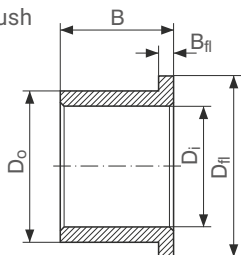

Thrust washer

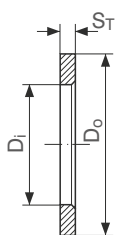

Slideplate

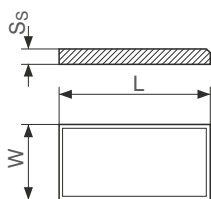

Special parts (sketch)

### DIMENSIONS [MM]

Inside diameter	$D_i$	
Outside diameter	$D_o$	
Length	B	
Flange Diameter	$D_{fl}$	
Flange thickness	$B_{fl}$	
Wall thickness	$S_T$	
Length of slideplate	L	
Width of slideplate	W	
Thickness of slideplate	$S_s$	

### LOAD

<input type="checkbox"/> Static load	
<input type="checkbox"/> Dynamic load	
Axial load F	[N]
Radial load F	[N]

### MOVEMENT

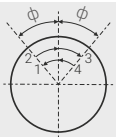
Rotational speed	N [1/min]	
Speed	U [m/s]	
Length of stroke	$L_s$ [mm]	
Frequency of stroke	[1/min]	
Oscillating cycle		$\phi$ [°]
Osc. frequency	$N_{osz}$ [1/min]	

### MATING SURFACE

Material		
Hardness	HB/HRC	
Surface finish	Ra [µm]	

### CUSTOMER INFORMATION

Company \_\_\_\_\_  
 Street \_\_\_\_\_  
 City / State / Province / Post Code \_\_\_\_\_  
 Telephone \_\_\_\_\_ Fax \_\_\_\_\_  
 Name \_\_\_\_\_  
 Email Address \_\_\_\_\_ Date \_\_\_\_\_

### FITS & TOLERANCES

Shaft	$D_J$	
Bearing housing	$D_H$	

### OPERATING ENVIRONMENT

Ambient temperature	$T_{amb}$ [°]	
Bearing housing material		
<input type="checkbox"/> Housing with good heating transfer properties		
<input type="checkbox"/> Light pressing or insulated housing with poor heat transfer properties		
<input type="checkbox"/> Non metal housing with poor heat transfer properties		
<input type="checkbox"/> Alternate operation in water and dry		

### LUBRICATION

<input type="checkbox"/> Dry		
<input type="checkbox"/> Continuous lubrication		
<input type="checkbox"/> Process fluid lubrication		
<input type="checkbox"/> Initial lubrication only		
<input type="checkbox"/> Hydrodynamic conditions		
Process fluid		
Lubricant		
Dynamic viscosity	$\eta$ [mPas]	

### SERVICE HOURS PER DAY

Continuous operation		
Intermittent operation		
Operating time		
Days per year		

### SERVICE LIFE

Required service life	$L_H$ [h]	
-----------------------	-----------	--



# Product Information

---

GGB assures the products described in this document have no manufacturing errors or material deficiencies.

The details set out in this document are registered to assist in assessing material suitability for intended use. They have been developed from our own investigations as well as generally accessible publications. They do not represent any assurance for the properties themselves.

Unless expressly declared in writing, GGB gives no warranty that the products described are suited for any particular purpose or specific operating circumstances. GGB accepts no liability for any losses, damages, or costs however they may arise through direct or indirect use of these products.

GGB's sales and delivery terms and conditions, included as an integral part of quotations, stock and price lists, apply absolutely to all business conducted by GGB. Copies can be made available on request.

Products are subject to continual development. GGB retains the right to make specification amendments or improvements to technical data without prior announcement. Edition 2023 (this edition replaces earlier editions which hereby lose their validity).

## STATEMENT REGARDING LEAD CONTENT IN GGB PRODUCTS & EU DIRECTIVE COMPLIANCE

GGB is committed to adhering to all U.S., European, and international standards and regulations with regard to lead content. We have established internal processes that monitor any changes to existing standards and regulations, and we work collaboratively with customers and distributors to ensure all requirements are strictly followed. This includes RoHS and REACH guidelines.

GGB makes it a top priority to operate in an environmentally conscious and safe manner. We follow numerous industry best practices and are committed to meeting or exceeding a variety of internationally recognized standards for emissions control and workplace safety.

Each of our global locations has management systems in place that adhere to IATF 16949, ISO 9001, ISO 14001, ISO 45001, and AS9100D/EN9100 quality regulations.

All of our certificates can be found here: <https://www.ggbearings.com/en/certificates>. A detailed explanation of our commitment to REACH and RoHS directives can be found at <https://www.ggbearings.com/en/who-we-are/quality-and-environment>.

GGB®, DU® and DU-B are registered trademarks or trademarks, as the case may be, of GGB and its affiliates.

Any use of GGB's trademarks without GGB's prior written permission is strictly prohibited.

©2023 GGB. All rights reserved.



PUSHING BOUNDARIES TO CO-CREATE  
A HIGHER QUALITY OF LIFE



**GGB HEILBRONN GMBH**

Ochsenbrunnenstr. 9 | D-74078 Heilbronn

Tel: +49 7131 269 0

[www.ggbearings.com/de](http://www.ggbearings.com/de)



HB103ENG03-23HN